



KITZ10x

Interface Units

The KITZ 101 and KITZ102 interface units provide conversion for the Courier protocol from the K-Bus physical connection and format to EIA (RS)232 physical connection and IEC 60870 FT1.2 format.

KITZ10x allows either a PC running Courier master software, for example S1 Agile Toolsuite, or a Courier master programmed into an RTU/Bay computer to access the IED data. The Courier language was developed specifically for communications with substation devices such as relays and measurement devices.

Therefore through the use of KITZ and the Courier Protocol, the user has access to the device menu structure called the Courier Database.

This enables the reading and changing of device functions, settings, measurements or statistics. Courier protocol is most commonly used as a K-Bus system, consisting of a screened twisted pair of wires. This arrangement is suitable for communicating with up to 32 devices at a maximum distance of 1 km in electrically hostile environments.

Models Available

2 KITZ Models are available in the KITZ10x range: they are functionally identical.

- KITZ101
Interface suitable for desktop use
- KITZ102
Interface suitable for use at rear of the panel

Key Benefits

- Communicate with any K-Bus device
- Simple EIA232 connections
- Local or remote connections
- Suitable for desktop or substation locations
- Designed to same high standards as protection relays



Application

The KITZ101/102 interface may be used to interface between 1 and 32 Courier devices via:

PC serial port for local substation use:

- Compatible modems and telephone networks for remote access
- RTU (Remote Terminal Unit) for integration in SCADA systems with Courier protocol capability

The KITZ101/102 converts K-Bus to IEC 60870 FT1.2 frame format for use in computer based systems. It is typically applied in substations where a number of compatible devices could be located, along with connection equipment such as modems, RTU's or other SCADA equipment.

KITZ can provide local and remote access via K-Bus for settings changes, disturbance and event record extraction and also for circuit breaker operations.

KITZ101/102 may be integrated into intelligent SCADA systems where all or part of the system is available on the Courier protocol. Such systems simply require an EIA232 or fibre optic (via converters) port on the SCADA or RTU for connection to the KITZ101/102. SCADA systems without the Courier protocol may also utilise KITZ by use of other protocol converters, for example KITZ202 for Modbus or KITZ204 for IEC 60870-5-103 based systems.

Typical application of the KITZ101/102 is shown in figures 1 and 2.

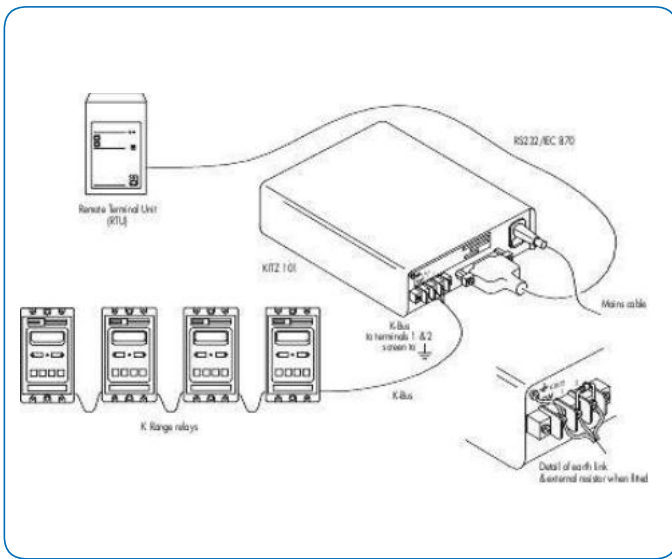

Figure 1: Typical application of KITZ101

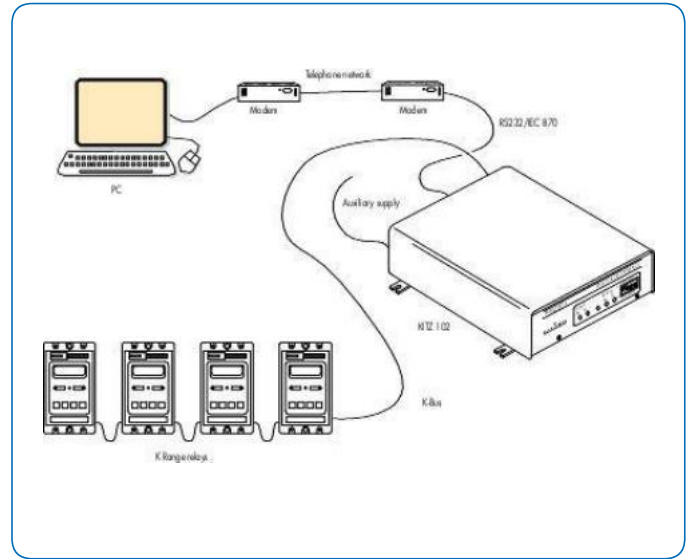

Figure 2: Supervision of tripping relay type MVAJ

Functions

Functions of KITZ101/102:

- Interface between K-Bus and IEC 60870 FT1.2 data formats
- Modem interface
- Time-tagging of K-Bus messages

The main function of the KITZ101/102 is to interface the K-Bus communications link with a PC based system (IEC 60870 FT1.2 data format).

It can also be configured to interface with a remote master station. Communications may be established via telephone networks and modems to access the devices in much the same way as a local connection.

In addition, it is also possible to configure the KITZ101/102 to add an IEC 60870 FT1.2 format date and time tag to any received K-Bus messages that contain an unsynchronised millisecond counter. This allows accurate sequence of events (SOE) despite modem or transmission delays on the IEC 60870 FT1.2 network. The internal Real Time Clock is backed up by an internal battery in case of loss of power.

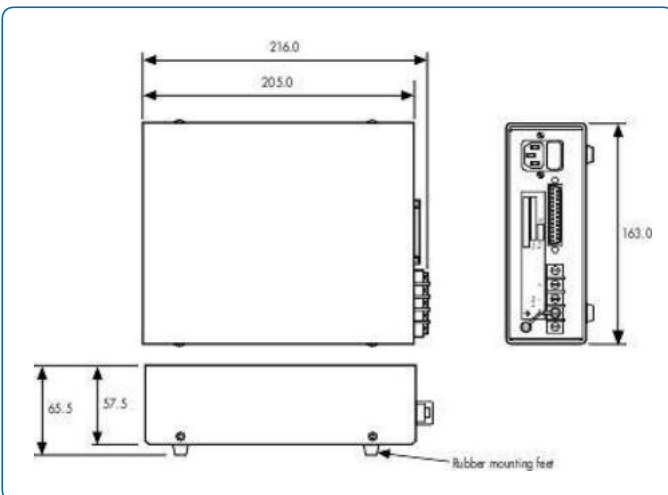

Figure 4: Case Outline for KITZ101

Hardware Description

The KITZ10x interfaces are housed in a case sized:

57.5 mm x 163 mm x 216 mm.

These are available for desktop (KITZ101) or rear of panel mounting (KITZ102).

The KITZ10x has two communications channels, one K-Bus and one EIA(RS)232/IEC60870 FT1.2, each able to receive and transmit via independent communications ports. Both RS232 and K-BUS ports are located at the rear of the KITZ10x. The K-BUS port is a 3 terminal connection (2 signal plus screen) and is not polarity sensitive. The RS232 port is a male 25 way D-Type connection, which normally requires a switched or 'null-modem' connection as it is a DTE interface.

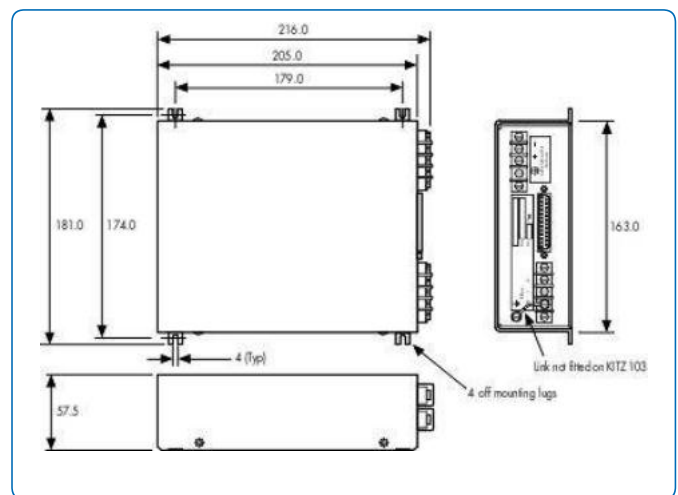

Figure 5: Case Outline for KITZ102

User Interfaces

Front Panel

The front of the KITZ10x interfaces contain 5 LED's to indicate:

- Power On
- Transmit K-Bus
- Receive K-Bus
- Transmit IEC 870
- Receive IEC 870

Eight switches are also located alongside the LED's for configuration of the interface.

Communications Interface

KITZ10x interfaces support a variety of Courier based communications packages. S1 Agile Toolsuites enable communications with the rear ports of any connected Courier devices, allowing full configuration as if it were the front port. This allows configuration of the full K-BUS spur of devices without the need for separately connecting cables to each device's front port. The process can even be carried out remotely by use of a suitable modem. Previous versions of software such as MiCOM S1 V2, Courier Access (CAS), Protection Access Software & Toolkit (PAS&T), COURIERCOMM, LFZRCOM or OPTICOM (KITZ103 - subject to version) also function well with KITZ10x, maintaining important backward compatibility.

For more information please contact
GE
Grid Solutions

Worldwide Contact Center

Web: www.GEGridSolutions.com/contact
Phone: +44 (0) 1785 250 070

GEGridSolutions.com

IEC is a registered trademark of Commission Electrotechnique Internationale. IEEE is a registered trademark of the Institute of Electrical Electronics Engineers, Inc.

GE and the GE monogram are trademarks of General Electric Company.

GE reserves the right to make changes to specifications of products described at any time without notice and without obligation to notify any person of such changes.

KITZ10x-Brochure-EN-2018-12-Grid-GA-0739. © Copyright 2018, General Electric Company. All rights reserved.



Imagination at work