

GE
Grid Solutions

MMLZ

Technical Data Sheet
Auxiliary Modules

Publication reference: MMLZ/EN TDS/C



FEATURES

- Wide choice of application specific models
- Fully compatible with other Midos equipment
- Suitable for rack or panel mounting



Figure 1: Typical MMLZ module (MMLZ 07 shown)

INTRODUCTION

The MMLZ range of modules consists of various non-protective devices, which have been accommodated in standard Midos cases. The modules, each of which has been designed for a specific purpose, are fully compatible with the Midos range.

Models	
MMLZ01	Acceleration test module
MMLZ02	Blocking test module
MMLZ03	Protection in/out module
MMLZ04	Zone 2 override/normal switch module
MMLZ05	Blocking in/out module
MMLZ06	High impedance busbar switch module
MMLZ07	Channel test switch
MMLZ08	Auto reclose switching module
MMLZ09	Interrupt breaker fail switch module
MMLZ10	Protection in/out selector switch module
MMLZ11 MITZ01	Loopback test facility
MMLZ 15	Auto-reclose switching module
MMLZ 16	Auto-reclose switching module
MMLZ18	Channel test switch - send only
MMLZ 19	Channel test switch - receive only
MMLZ 20	Channel test switch - intertrip
MMLZ 21	Channel test switch - intertrip
MMLZ 22	Channel test switch - blocking
MMLZ 23	Channel test switch - triangulated intertrip
MMLZ 24	Channel test switch - receive intertrip
MMLZ 25	Channel test switch - single end intertrip
MMLZ 26	Channel selector switch
MMLZ 27	Channel selector switch
MMLZ 28	Switching module - K/MiCOM schemes
MMLZ 29	Switching module and CB indication - K/MiCOM schemes
MMLZ 30	Test Switch Module for Cascade Intertripping
MMLZ 31	Switching module and CB indication - K/MiCOM schemes

APPLICATIONS

The MMLZ modules cater for a variety of applications with each individual module being designed for a specific function. A selection of switch modules is available for use in, for example, distance, blocking, auto-reclose, breaker fail or high impedance busbar switching schemes, whilst others have been designed for on-site testing of signalling equipment.

The switches may be multi-way multi-position and can be spring return depending on the module type. Similarly, the switches may be key operated or fitted with an adjacent key operated locking device.

Functions	
For the convenience of the following descriptions, certain MMLZ modules are grouped together according to similarity of design.	
MMLZ 01 acceleration test module	The MMLZ 01 module is designed to provide a convenient method of performing on-site testing of different signalling equipment. The front plate (see Figure 2(a)) contains test plug sockets, for external inputs, and a 4-position rotary switch to select either normal operation or one of three alternative test modes. This switch is locked into its selected position and is only released by means of its adjacent key operated cylinder lock. The test signal is transmitted by momentary action pushbutton operation and two indicator lamps to show test status. The MMLZ 01 circuit diagram is shown in Figure 4.
MMLZ 02 blocking test module	The MMLZ 02 is similar in layout (see Figure 2(b)) and function to the MMLZ 01, except for its rotary switch which has three positions. The three position rotary switch selects either normal operation or one of two test modes. The MMLZ 02 circuit diagram is shown in Figure 5.
MMLZ 07 channel test switch module	The MMLZ 07 differs from the MMLZ 01 in that it is used for testing an intertwining channel. Figure 1(g) shows the front plate layout which differs from the other two because the 'test signal received' light is omitted. The MMLZ 07 diagram is shown in Figure 10).
MMLZ 03 protection in/out switch module	The front plate layouts of these key operated switching modules are shown in Figures 2(c) and 2(j) respectively. The MMLZ 03 module consists of a three position spring return to neutral switch whereas the MMLZ 10 has a two position switch.
MMLZ 10 protection in/out selector switch module	The MMLZ 03 can be arranged to operate an electrically reset relay such as the MVAJ 34. The MMLZ 10 is intended to be used without follower relays to provide direct isolation of circuits. The key can only be removed from the MMLZ 03 in the neutral position, whereas it is removable from either position in the MMLZ 10. The circuit diagrams of the switching modules are shown in Figures 6 and 13.
MMLZ 04 zone 2 override normal/switch module	The two modules can be used in, for example, distance protection schemes, and are identical, except for their labelling. The front plate layouts of the modules are shown in Figures 2(d) and 2(e) respectively.
MMLZ 05 blocking in/out module	Each module comprises one key operated three position, spring return to neutral switch that can be arranged to operate an electrically reset relay such as the MVAJ 34. The key is removable in the neutral position. Circuit diagrams for the modules are shown in Figures 7 and 8.
MMLZ 06 high impedance busbar switch module	The MMLZ 06 is suitable for in/out switching in a high impedance busbar scheme by means of a two position switch and is normally used without a follower relay. The front plate layout and circuit diagram are shown in Figures 2(f) and 9 respectively. Illuminated indication of the switch position is provided.

Functions	
MMLZ 08 auto reclose switch module	<p>The module is suitable for auto-reclose in/out switching on a one and a half switch arrangement where a separate switching relay is not fitted. The front plate layout is shown in Figure 2(h).</p> <p>The In/Out switch has two positions and is key operated. Two further non key operated, spring-return switches, each having two positions, are included to separately reset the lockout features associated with the two circuit breakers. The circuit diagram is shown in Figure 11.</p>
MMLZ 09 interrupt breaker fail switch module	<p>This module can be used to block the breaker fail circuit to prevent, for example, back trips during testing. The MMLZ 09 has a two-position stayput switch and operates without a follower relay to provide direct isolation of the circuit. The module has three labelling variations, depending on application, which are shown in Figure 2(i). See Figure 12 for the circuit diagram.</p>
MMLZ 11 - MITZ 01 loopback test facility	<p>The MMLZ 11 is used with the MITZ 01 interface unit. The interface unit allows the LFCB digital current differential relay to be connected through optical fibres to a remote multiplexer which has a CCITT G.703 co-directional interface.</p> <p>The MMLZ 11 is positioned in the G.703 interface immediately after the MITZ 01 unit. It enables the LFCB, the MITZ 01 and the cross-site optical link to be tested in a loopback mode.</p> <p>This is achieved by removal of four 'U-links' from the normal position, (see front plate layout in Figure 2(l)) and insertion into the test position.</p> <p>The MMLZ 11 and MITZ 01 combination can be applied to each of a two-ended feeder whereas for a three-ended feeder, two MMLZ 11 and MITZ 01 sets are required per line end. The module circuit diagram is shown in Figure 14.</p>

Switches	
MMLZ 15 and MMLZ 16 switching module	<p>The MMLZ 15 consists of 3 rotary switches each with 2 positions. It is used in NGC TPS 12/10 auto-reclose scheme. MMLZ 16 differs in that it has only 2 switches.</p> <p>The MMLZ 15 and MMLZ 16 front plate layouts are shown in Figure 2(k) and 2(m) respectively. See Figures 15 and 16 for the circuit diagrams.</p>
MMLZ 26 and MMLZ 27 channel selector switches	<p>MMLZ 26 and MMLZ 27 are simple 4 and 3 position selector switches respectively. The switches are locked into the selected position and can only be released by the adjacent key operated lock. Both switches were designed for use with a power line carrier intertripping scheme.</p> <p>The MMLZ 26 and MMLZ 27 front plate layouts are shown in Figures 3(u) and 3(v) respectively. See Figures 25 and 26 for the circuit diagrams.</p>

Switches	
MMLZ 28, MMLZ 29 and MMLZ 31 switching modules	<p>MMLZ 28 and MMLZ 29 have both been designed for use with K Range and MiCOM busbar schemes. The MMLZ 28 has 2 key operated switches. Each switch has 2 positions. One is 'Busbar/CB Fail - In/Out' and the other is 'Transfer trip - Master/Follower'. For each switch the key is removable in either position.</p> <p>The MMLZ 29 consists of 2 key operated switches. Each switch has 3 positions. The top switch has 2 user definable positions, the central position being 'Off' and has a maintained action. The positions in which the key can be removed and the label inscription can be selected by the user at order stage.</p> <p>The lower switch is 'Trip/Off/Close' and has a momentary action. The key can only be removed in the 'Off' position. There is also a Circuit Breaker position mimic.</p> <p>The MMLZ 28 and MMLZ 29 front plate layouts are shown in Figures 3(w) and 3(x) respectively. See Figures 27 and 28 for the circuit diagrams.</p> <p>The MMLZ 31 consists of 2 key operated switches. Each switch has 3 positions, the top switch is 'Trip/Normal/Close' and has a momentary action. The key can only be removed in the 'Normal' position. There is also a circuit breaker mimic. The bottom switch is 'Local/Off/Remote' and has a maintained action. The key can be removed in all positions.</p>

Channel Test Switches	
Channel test switches provide facilities for testing the correct operation of a channel and some also enable propagation time tests to be carried out.	
	<p>The MMLZ 01 module is designed to provide a convenient method of performing on-site testing of different signalling equipment. The front plate (see Figure 2(a)) contains test plug sockets, for external inputs, and a 4-position rotary switch to select either normal operation or one of three alternative test modes. This switch is locked into its selected position and is only released by means of its adjacent key operated cylinder lock. The test signal is transmitted by momentary action pushbutton operation and two indicator lamps to show test status. The MMLZ 01 circuit diagram is shown in Figure 4.</p>
MMLZ 18 channel test switch - intertrip schemes - send only	<p>MMLZ 18 - send only. The front plate consists of 1 key operated 2 position switch - Test/Normal, a momentary action pushbutton 'Signal Send' to transmit the test signal and 2 indicator lamps 'Normal' and 'Channel on Test' to indicate status. The key can be removed with the switch in either position. MMLZ 19 - Receive only.</p>
MMLZ 19 channel test switch - intertrip schemes - receive only	<p>The MMLZ 19 differs from the MMLZ 18 in that it has no pushbutton.</p> <p>The MMLZ 18 and MMLZ 19 front plate layouts are shown in Figures 3(n) and 3(o) respectively. See Figures 17 and 18 for the circuit diagrams.</p>
MMLZ 20 and MMLZ 21 channel test switch - intertrip	<p>MMLZ 20 and MMLZ 21 consist of 1 key operated 2 position switch - Test/Normal and 2 indication lamps to indicate status. The key can be removed with the switch in either position.</p> <p>These MMLZs are used for testing signalling channels in intertripping schemes without initiating the intertrip receive trip relays. Both are used in NGC TPS 5/33 schemes. MMLZ 20 is used in 'Intertrip 003' and MMLZ 21 is used in 'Intertrip 004'.</p> <p>The MMLZ 20 and MMLZ 21 front plate layouts are shown in Figure 3(p). See Figures 19 and 20 for the circuit diagrams.</p>

Channel Test Switches	
MMLZ 22 channel test switch - distance blocking schemes	<p>The MMLZ 22 consists of a momentary pushbutton 'Channel Test' and 2 indication lamps 'Carrier Test Ready' and 'Test Signal Received'.</p> <p>It is used in NGC TPS 5/33 schemes SHNB Block 002 and THR Block 002.</p> <p>The MMLZ 22 front plate layout is shown in Figure 3(q). See Figure 21 for the circuit diagram.</p>
MMLZ 23 channel test switch - triangulated intertrip scheme	<p>The front plate of the MMLZ 23 consists of a 4 position rotary selector switch comprising 1 normal and 3 test positions. The switch is locked into the selected position and can only be released by the adjacent key operated lock. There is a momentary action pushbutton to transmit the test signal and an indicator lamp 'Channel on Test'.</p> <p>There are also 2 test sockets - 'Initiate' and 'Reflex'.</p> <p>It is used in NGC TPS 5/33 scheme 'Intertrip 005'.</p> <p>The MMLZ 23 front plate layout is shown in Figure 3(r). See Figure 22 for the circuit diagram.</p>
MMLZ 24 channel test switch - receive intertrip scheme	<p>The MMLZ 24 differs from the MMLZ 23 in that the selector switch has only 3 positions comprising 1 normal and 2 test positions.</p> <p>This switch is used in a scheme where the receive trip relays are operated when the channel is tested but not when the timing test is carried out.</p> <p>It is used in NGC TPS 5/33 scheme 'Intertrip 007'.</p> <p>The MMLZ 24 front plate layout is shown in Figure 3(s). See Figure 23 for the circuit diagram.</p>
MMLZ 25 channel test switch - intertrip	<p>The front plate of the MMLZ 25 consists of a 3 position selector switch comprising 1 normal and 2 test positions, a momentary action pushbutton to transmit the test signal and an indicator lamp 'Channel on Test'. There are also 2 test sockets - 'Send Start' and 'Receive Output'.</p> <p>The switch is locked into the selected position and can only be released by the adjacent key operated lock.</p> <p>It is used in single end intertripping schemes.</p> <p>The MMLZ 25 front plate layout is shown in Figure 3(t). See Figure 24 for the circuit diagram.</p>

HARDWARE DESCRIPTION

The modules are housed in Midos cases, suitable for either rack or panel mounting as shown in Figure 29. Standard Midos terminal blocks are located at the rear of the module providing connection for all input and output circuits.

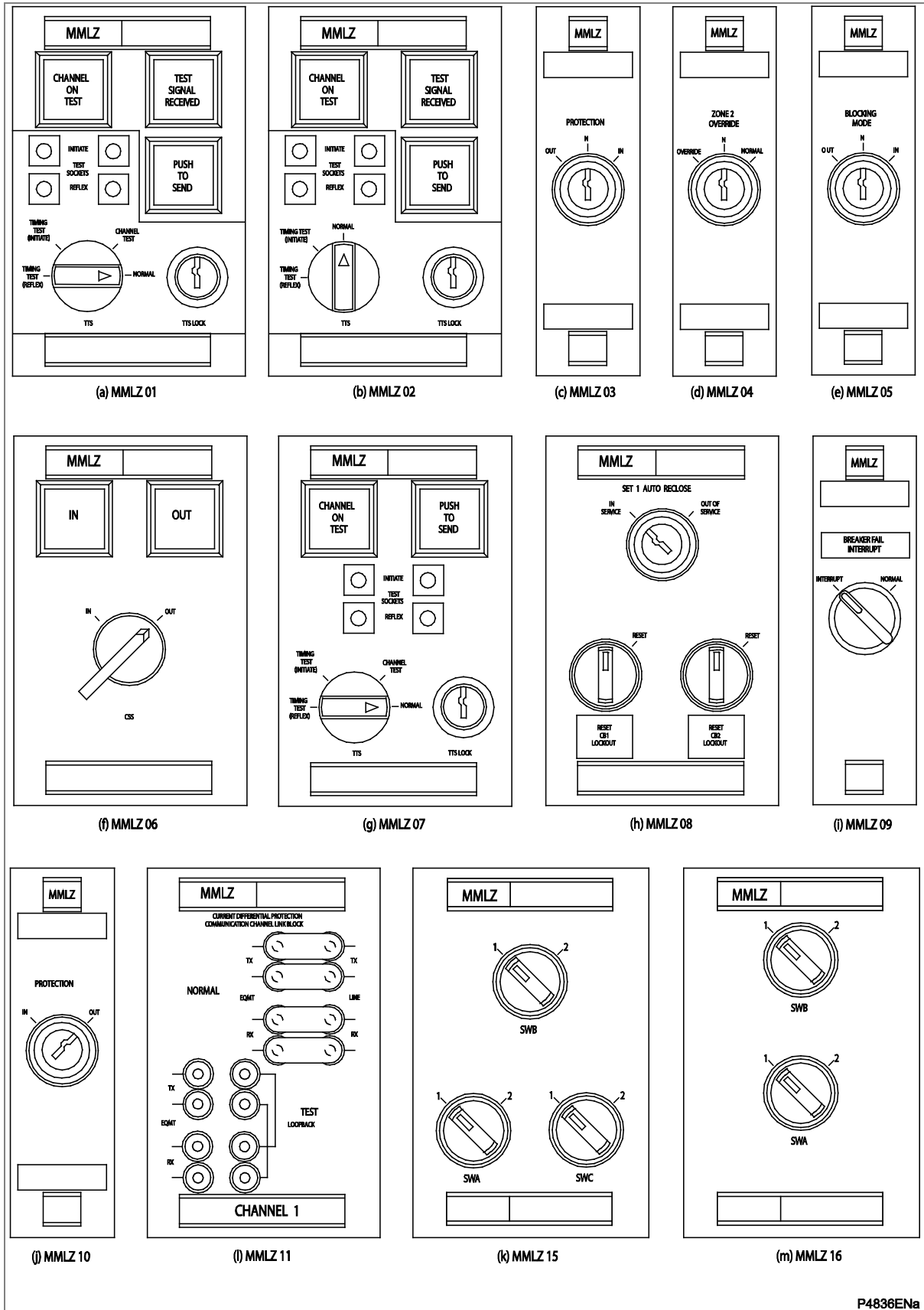

P4836ENa

Figure 2: Frontplate layouts MMLZ 01 to 16

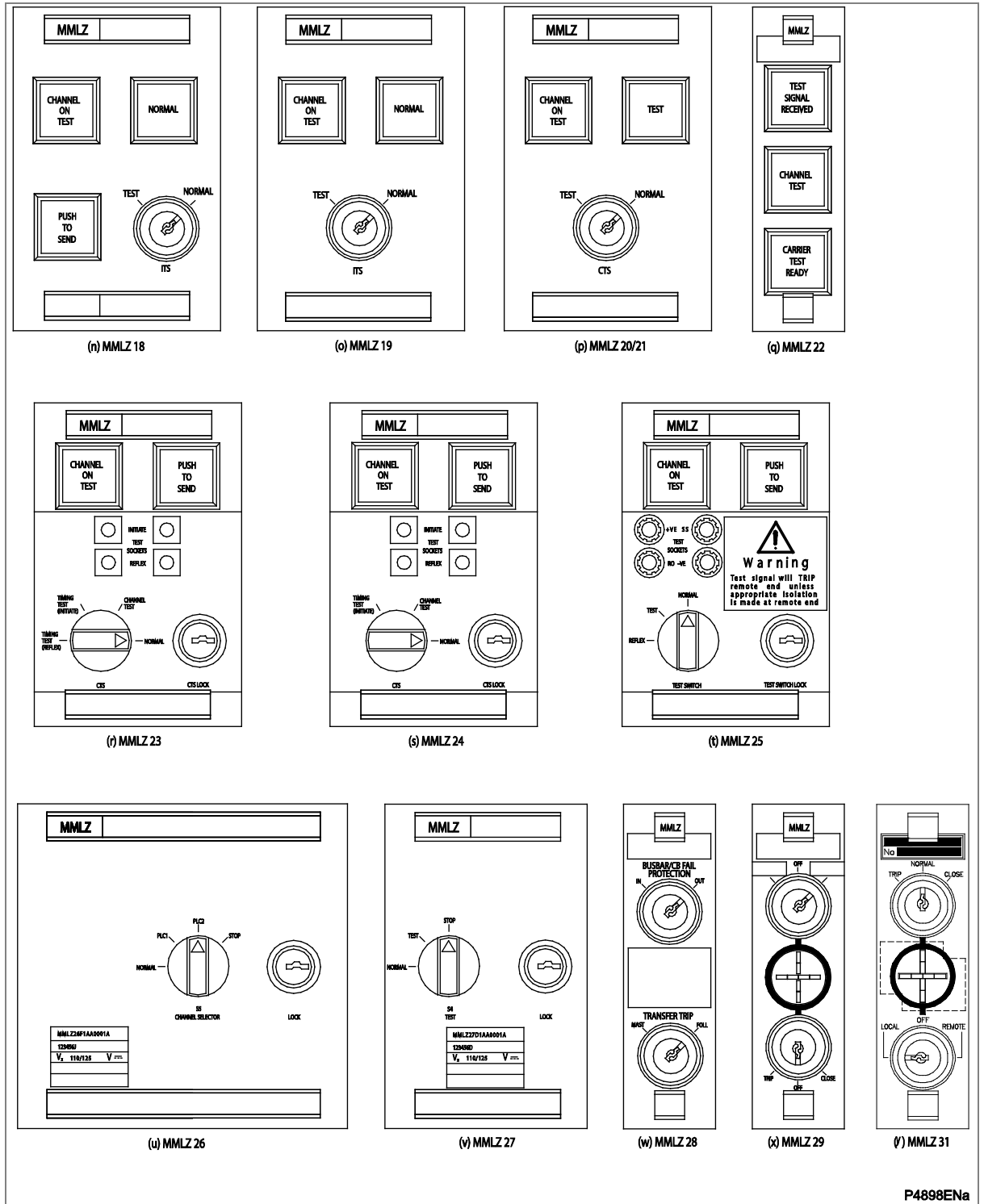

Figure 3: Frontplate layouts MMLZ 18 to 31

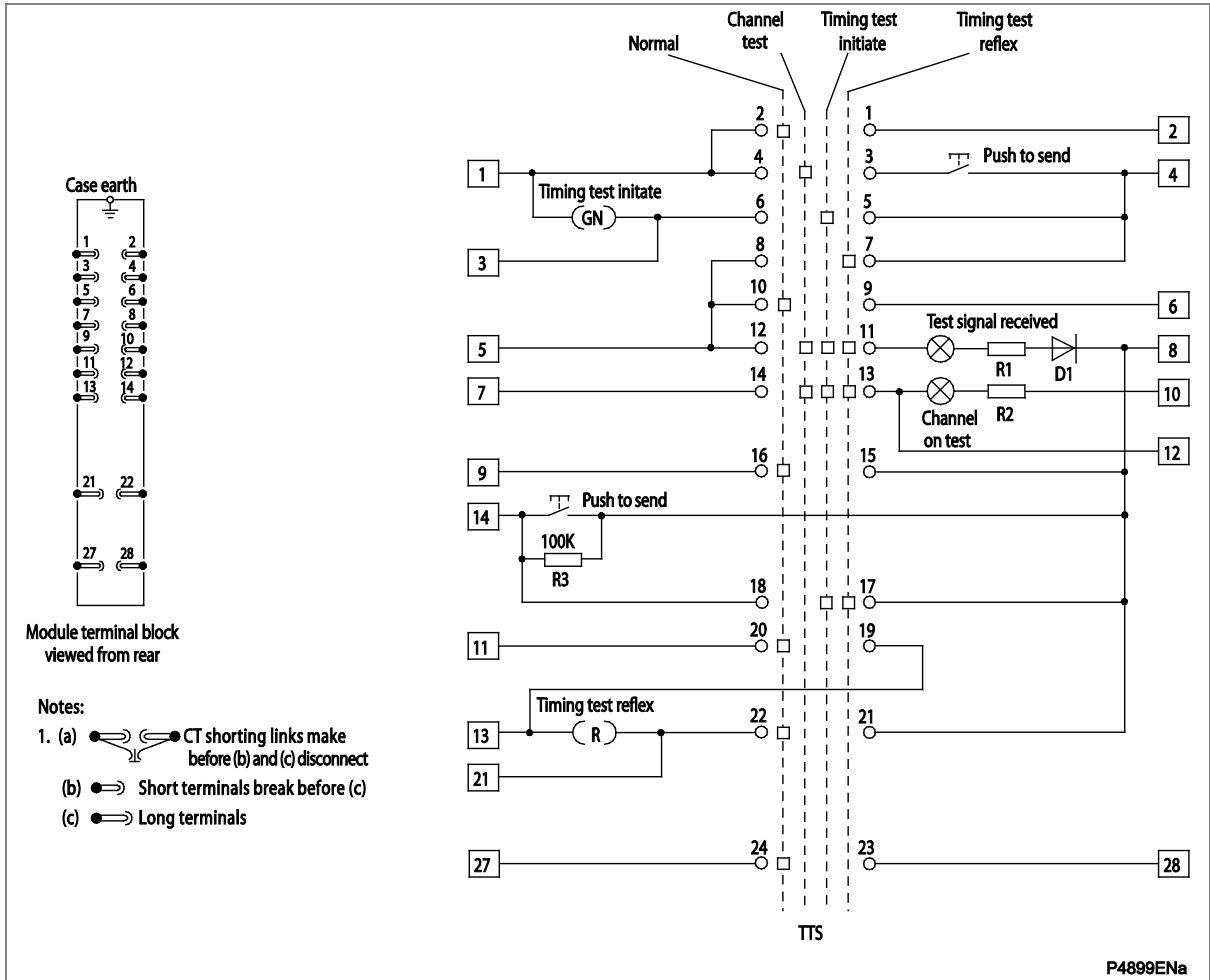

Figure 4: MMLZ 01 acceleration test module (typical only)

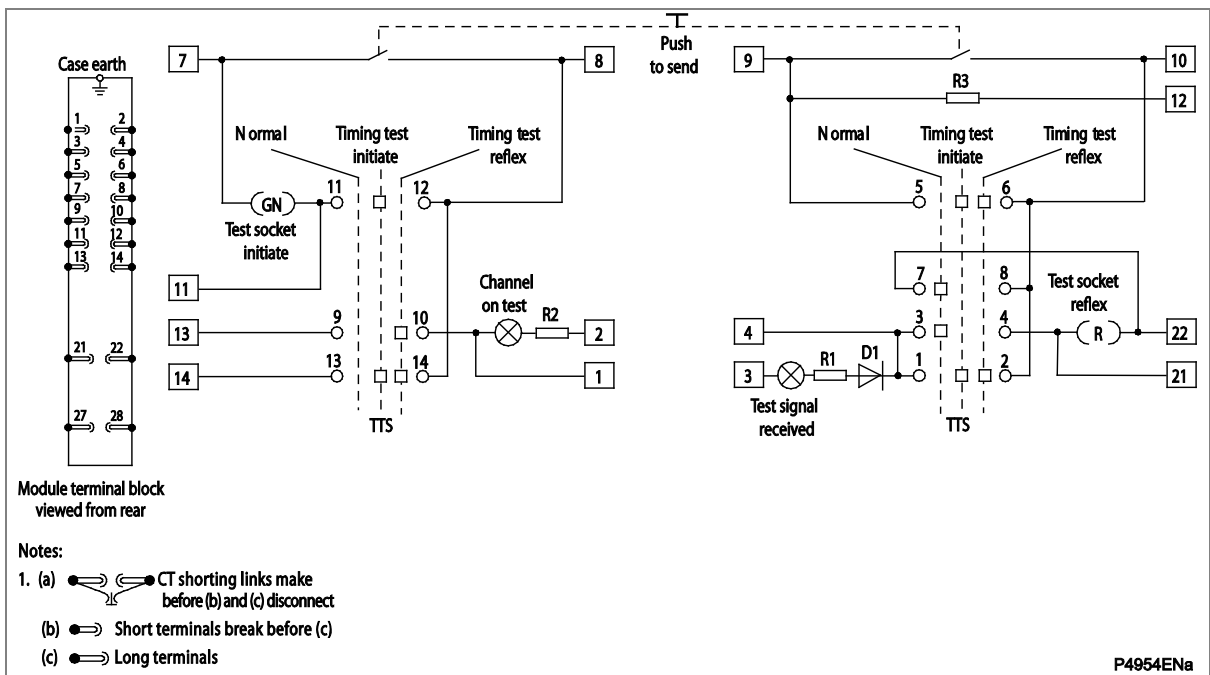

Figure 5: MMLZ 02 blocking test module

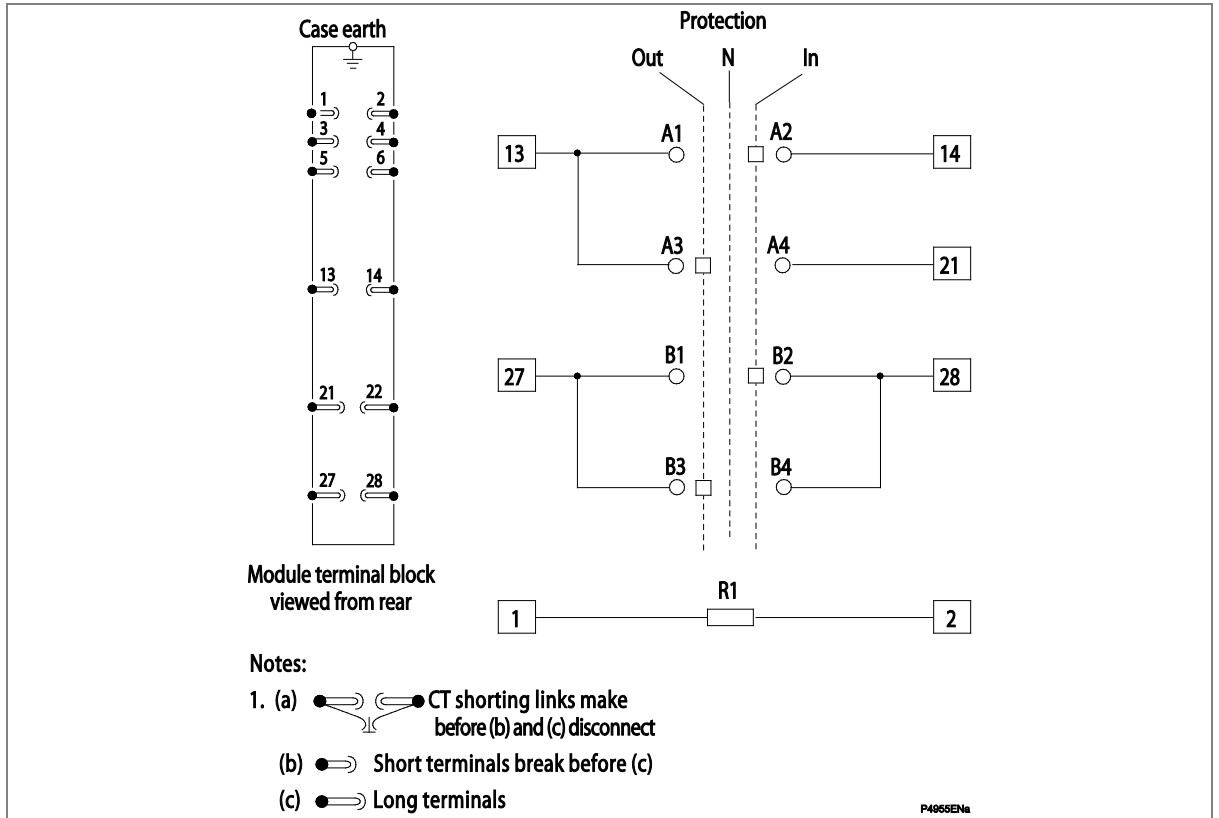

Figure 6: MMLZ 03 protection in/out switch module

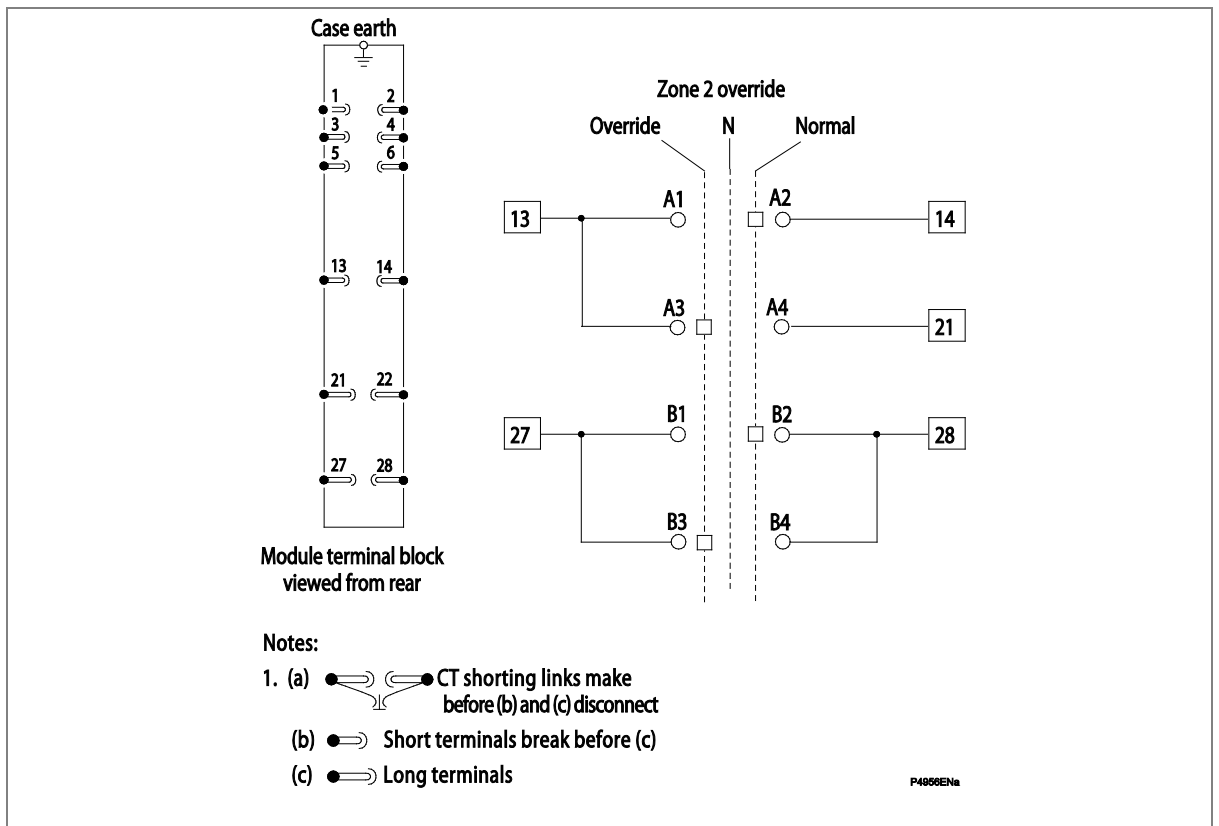

Figure 7: MMLZ 04 zone 2 override normal/switch module

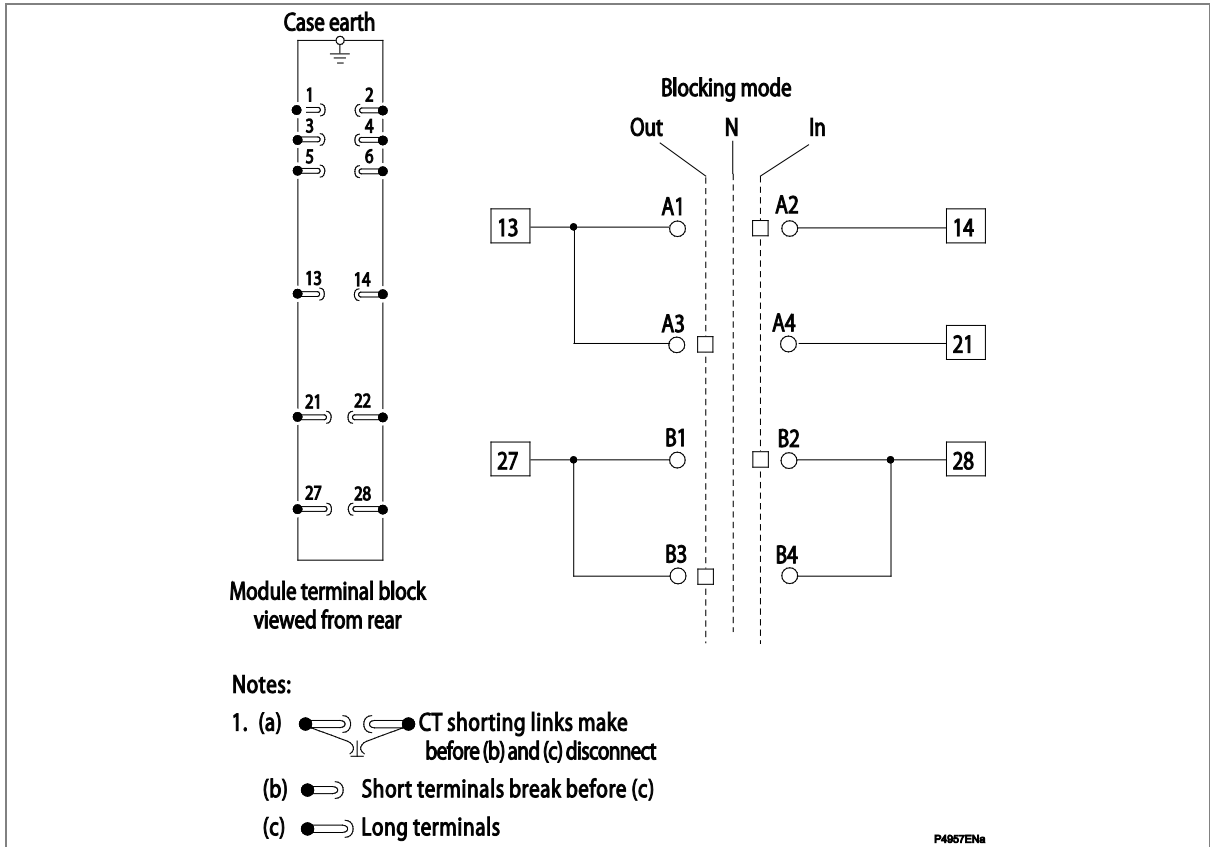

Figure 8: MMLZ 05 blocking in/out module

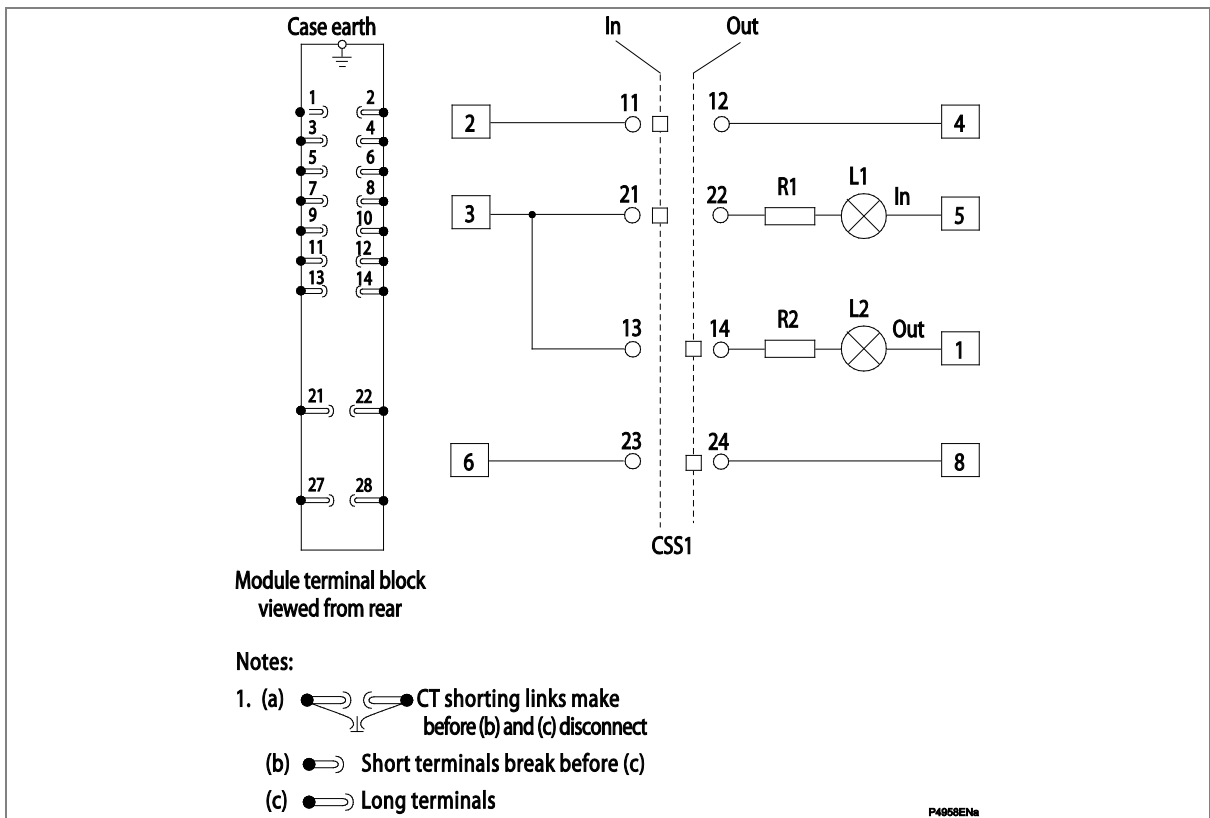

Figure 9: MMLZ 06 high impedance busbar switch module

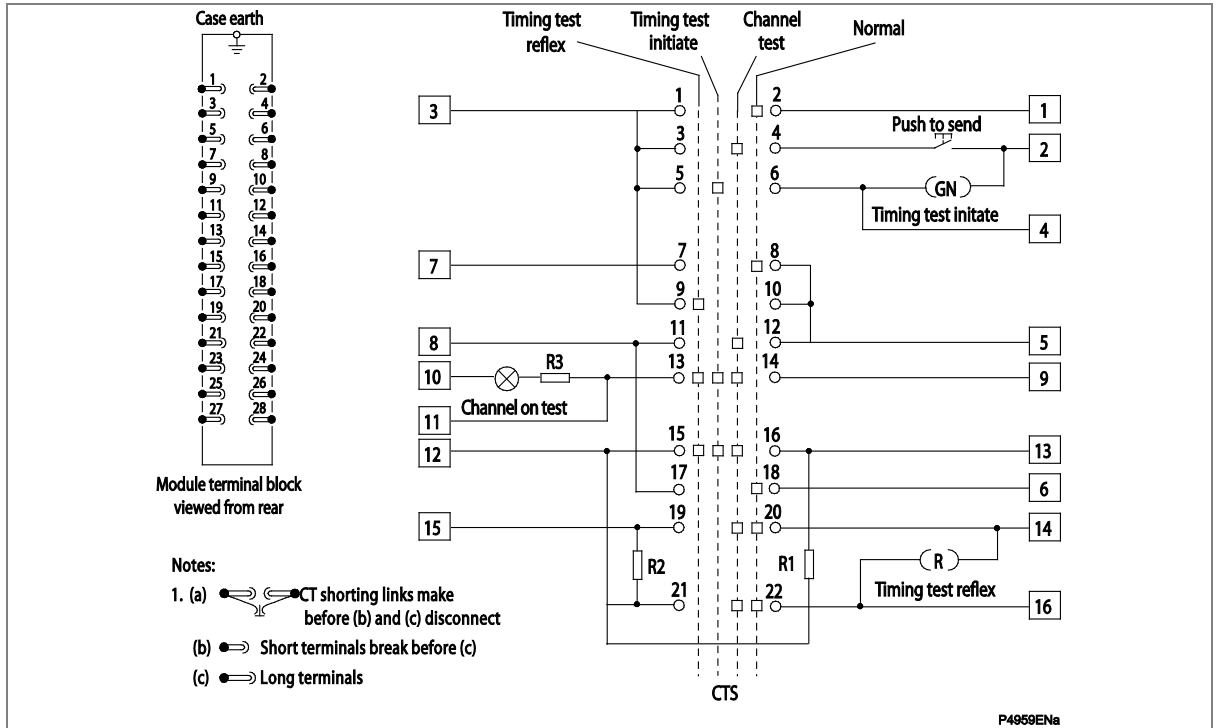

Figure 10: MMLZ 07 channel test switch module (typical only)

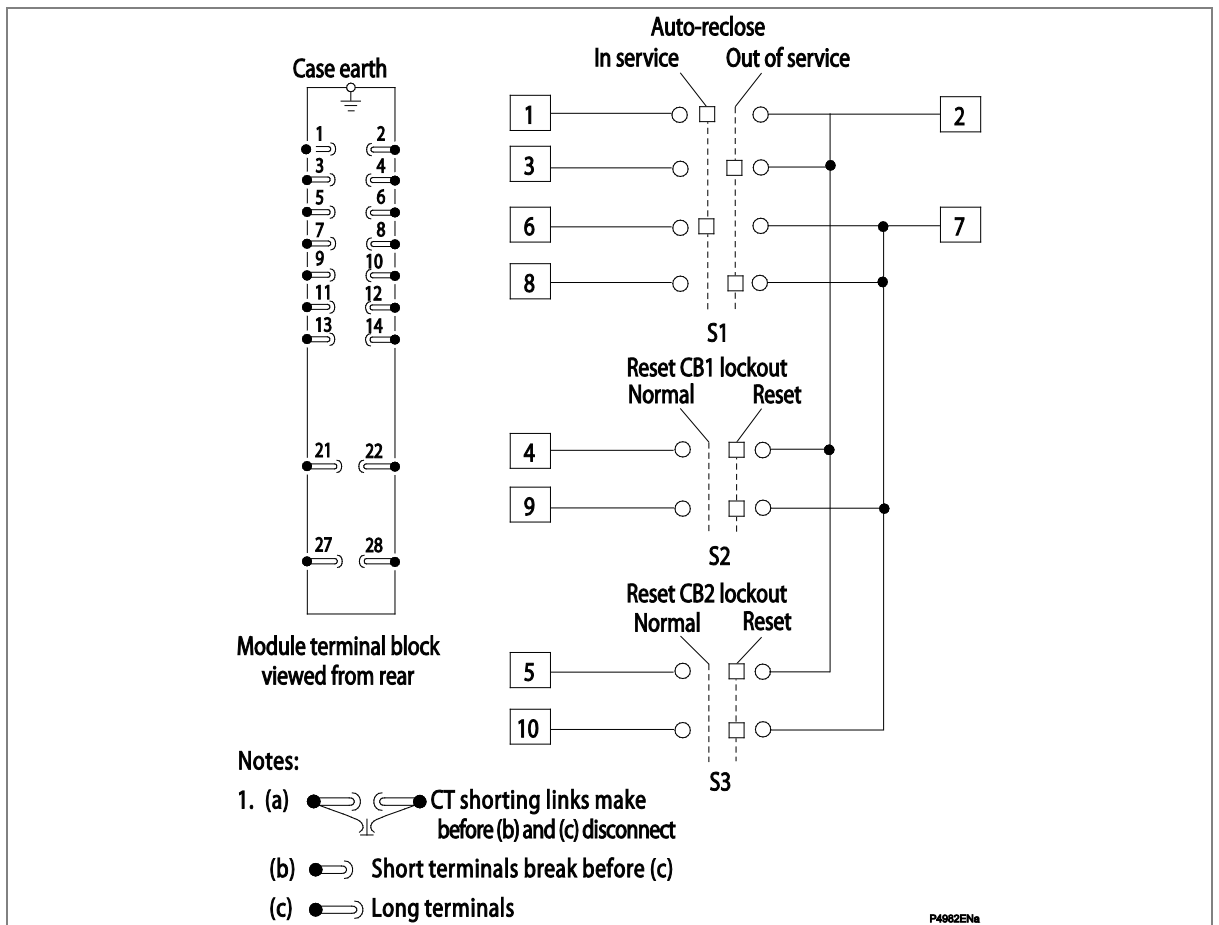

Figure 11: MMLZ 08 auto reclose switch module

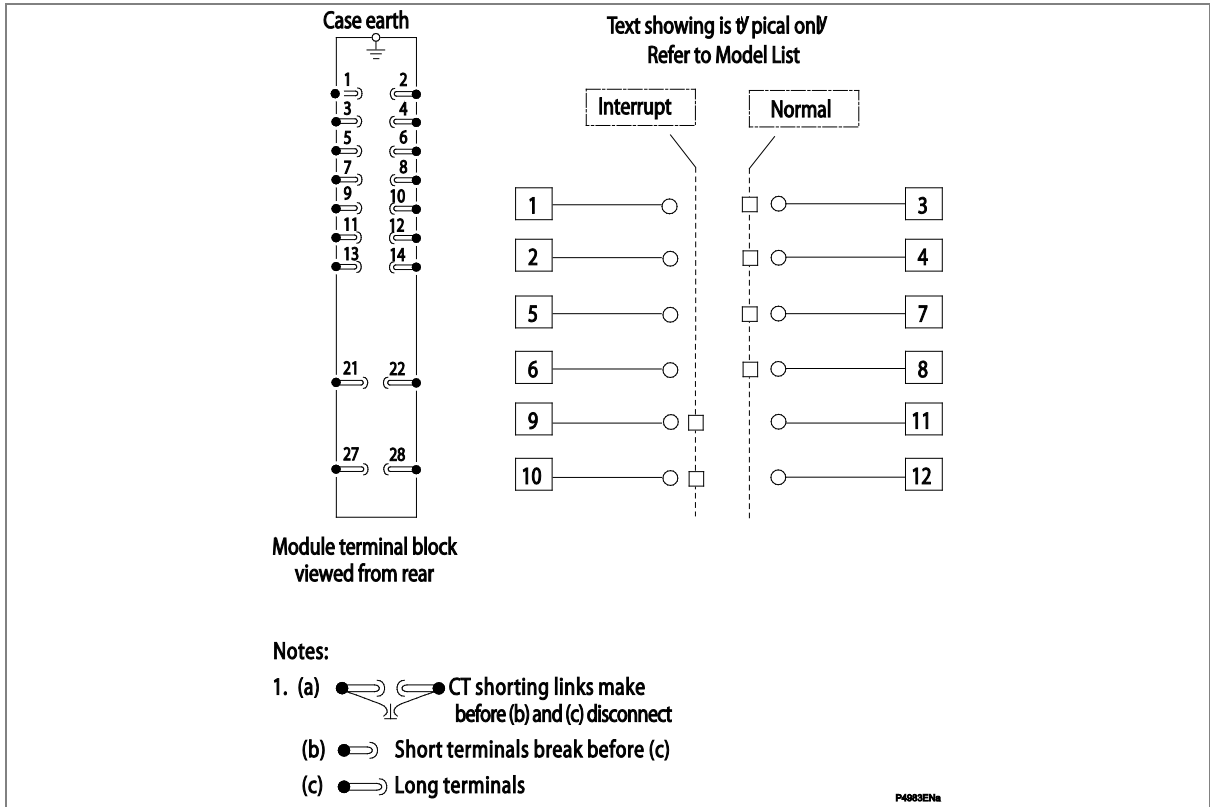

Figure 12: MMLZ 09 interrupt breaker fail switch module

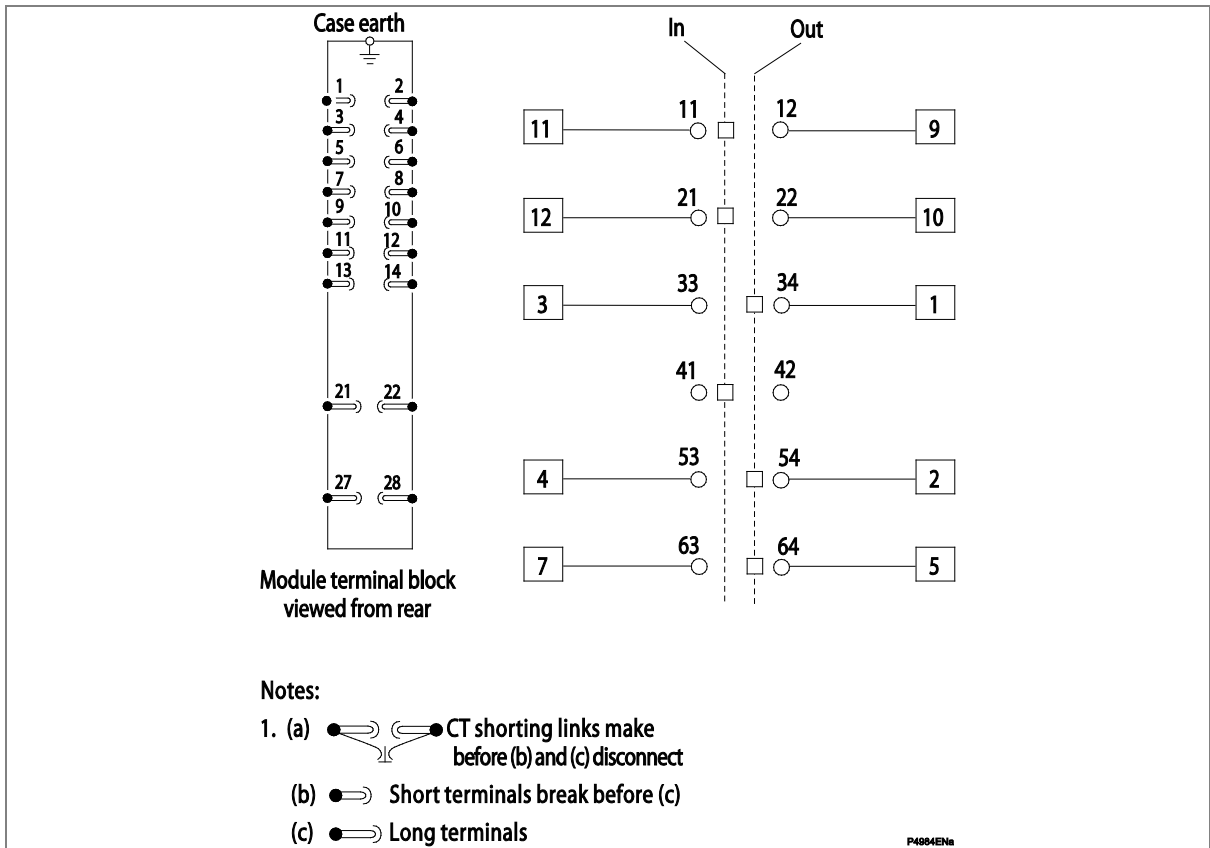

Figure 13: MMLZ 10 protection in/out selector switch module (typical only)

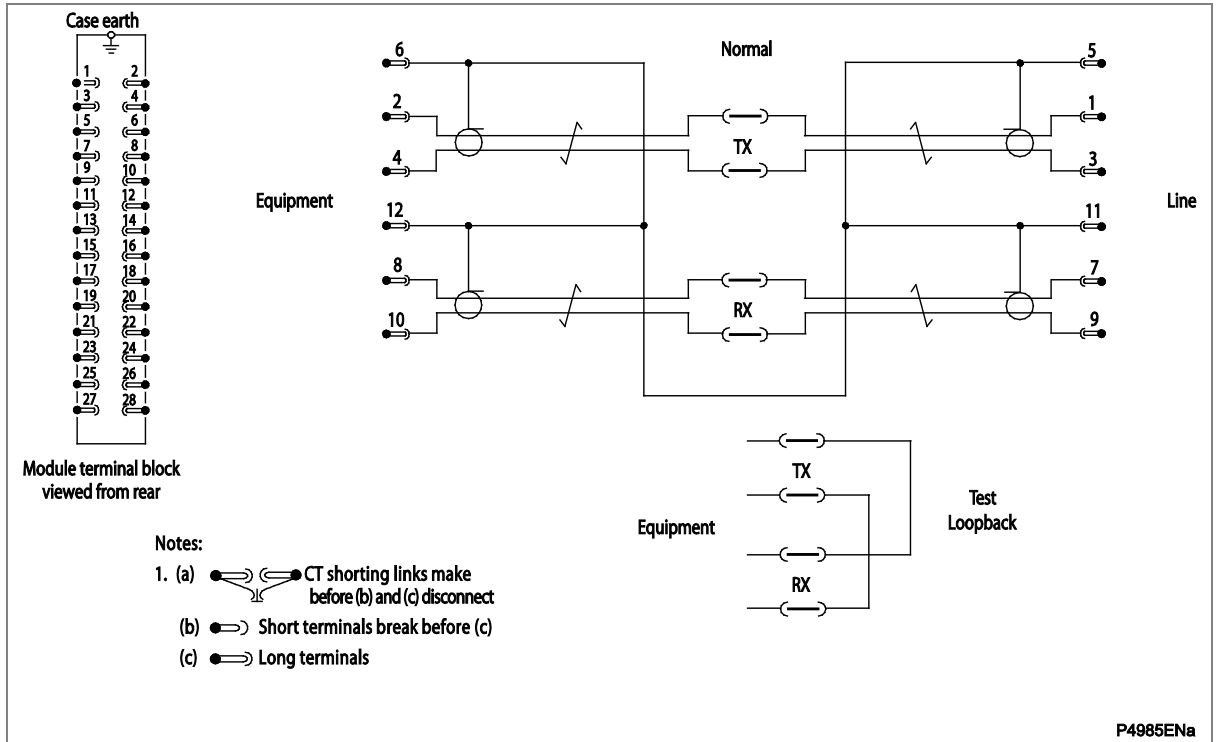

Figure 14: MMLZ 11 - MITZ 01 loopback test facility

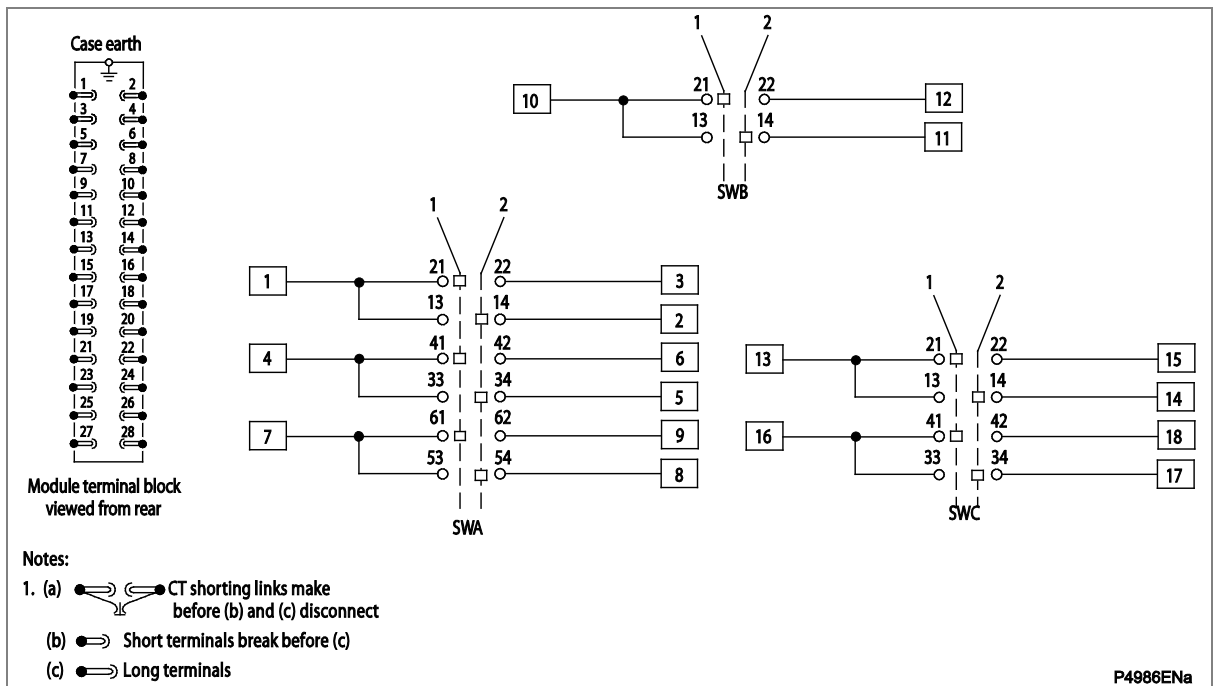

Figure 15: MMLZ switching module

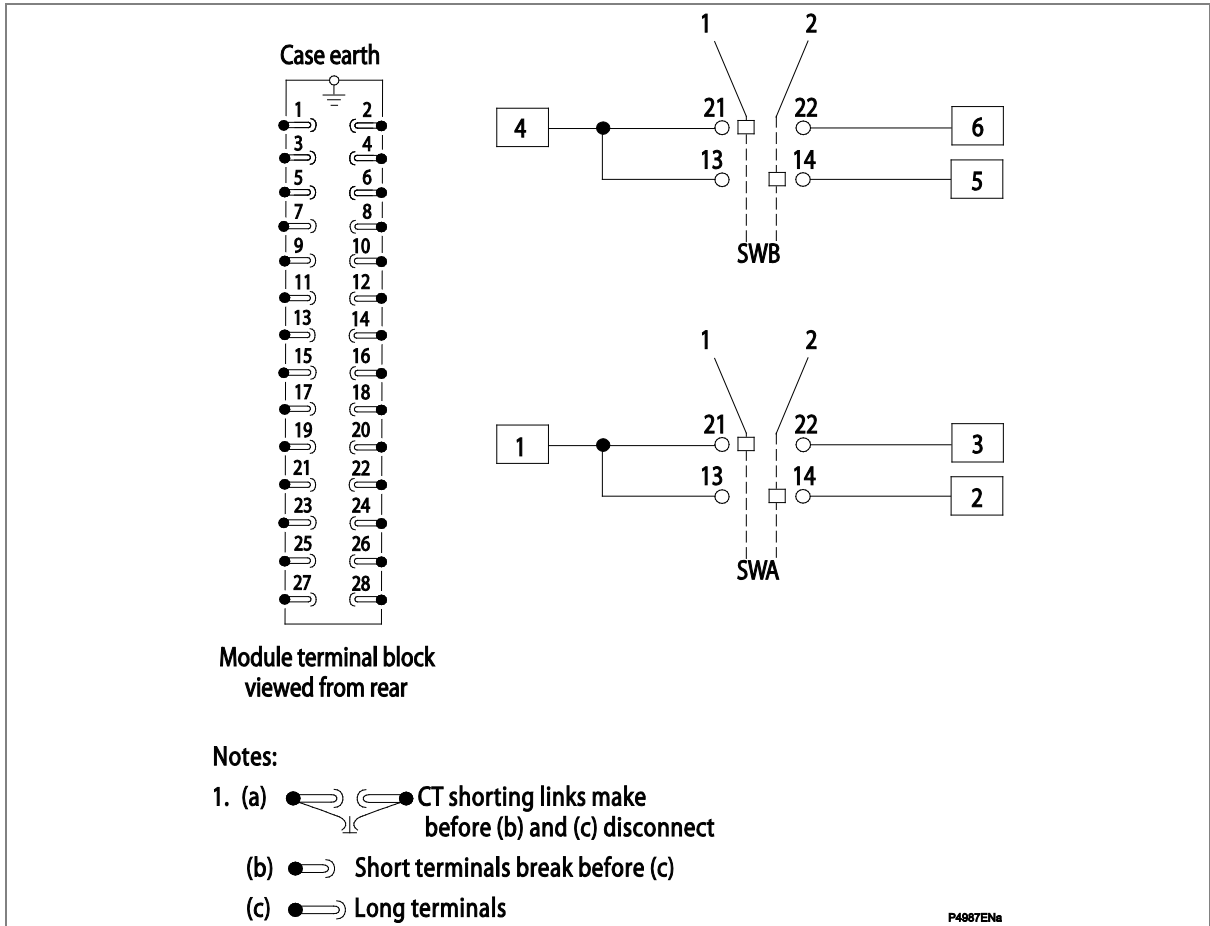

Figure 16: MMLZ 16 channel selector switches

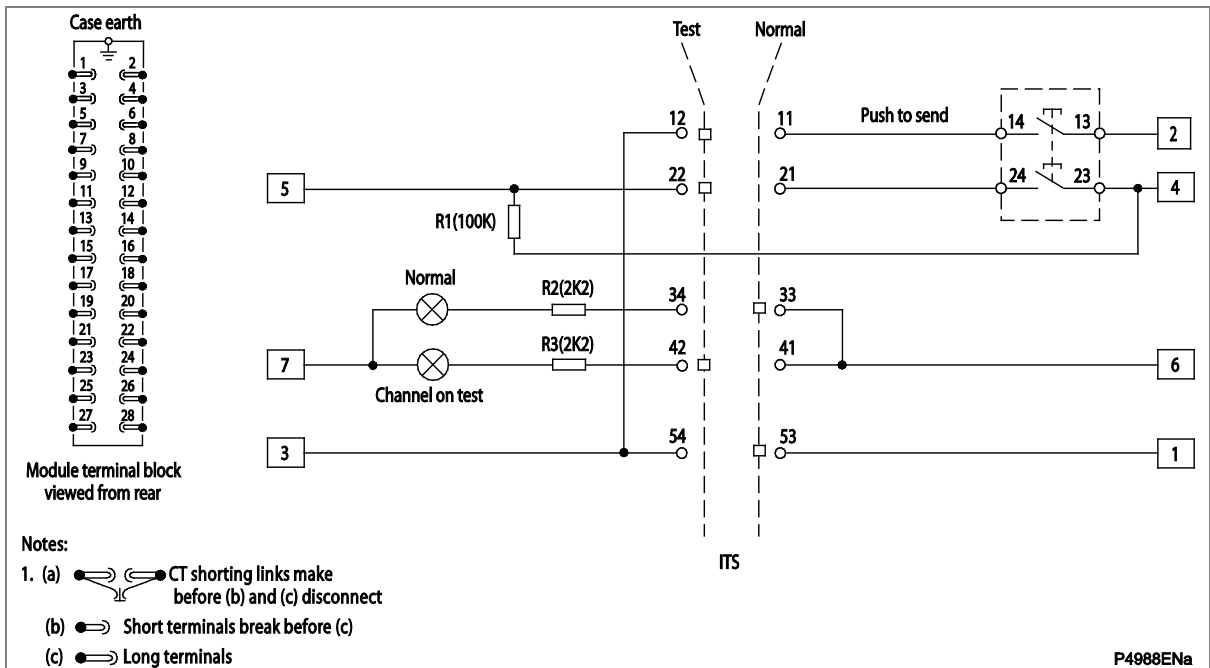

Figure 17: MMLZ 18 channel test switch - intertrip schemes - send only

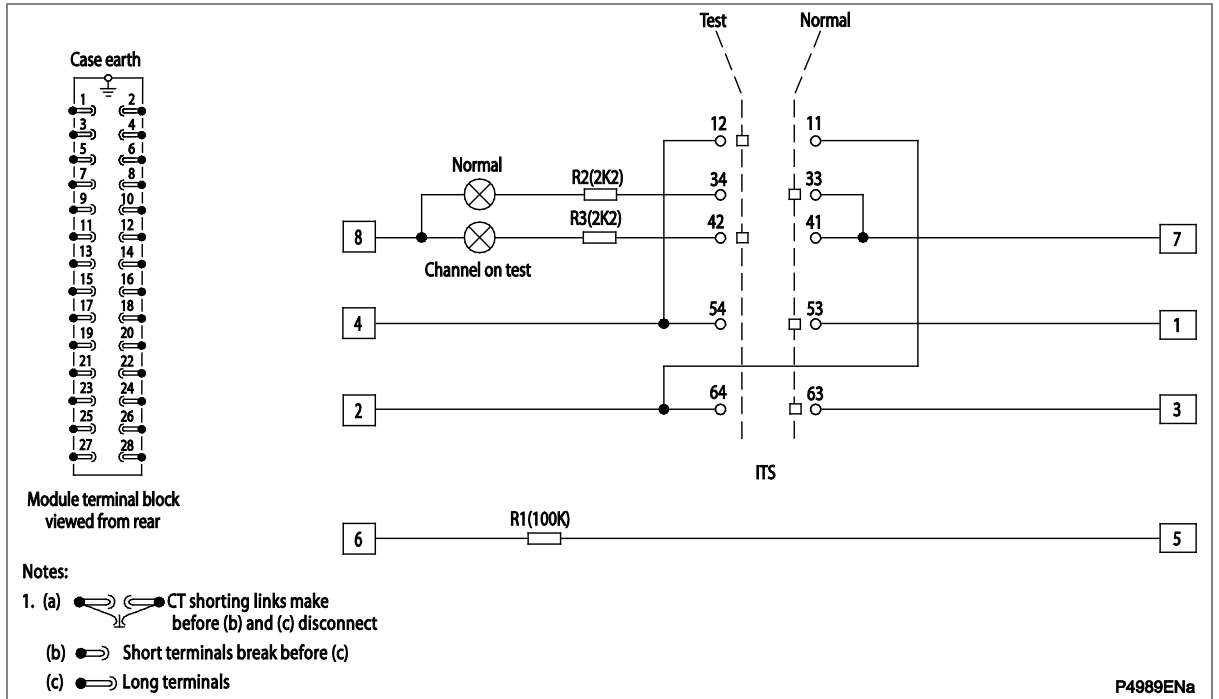

Figure 18: MMLZ 19 channel test switch - intertrip schemes - receive only

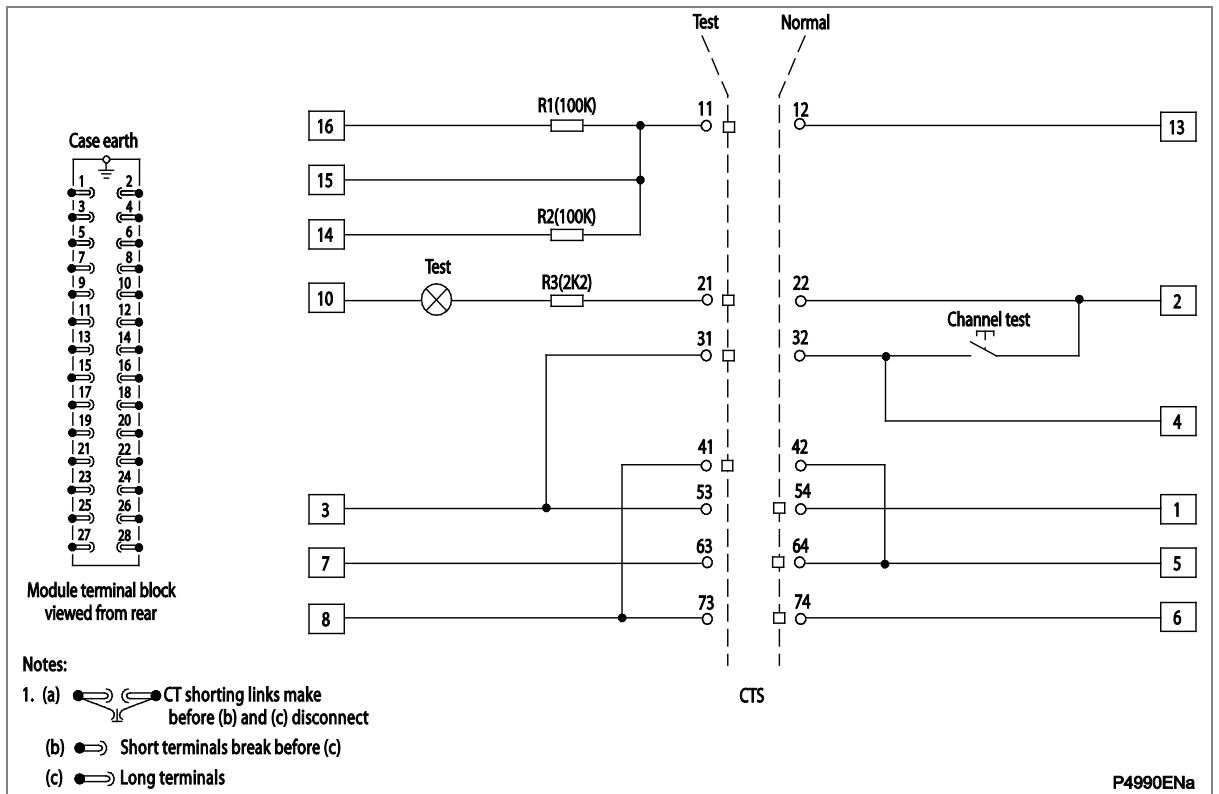

Figure 19: MMLZ 20 channel test switch - intertrip

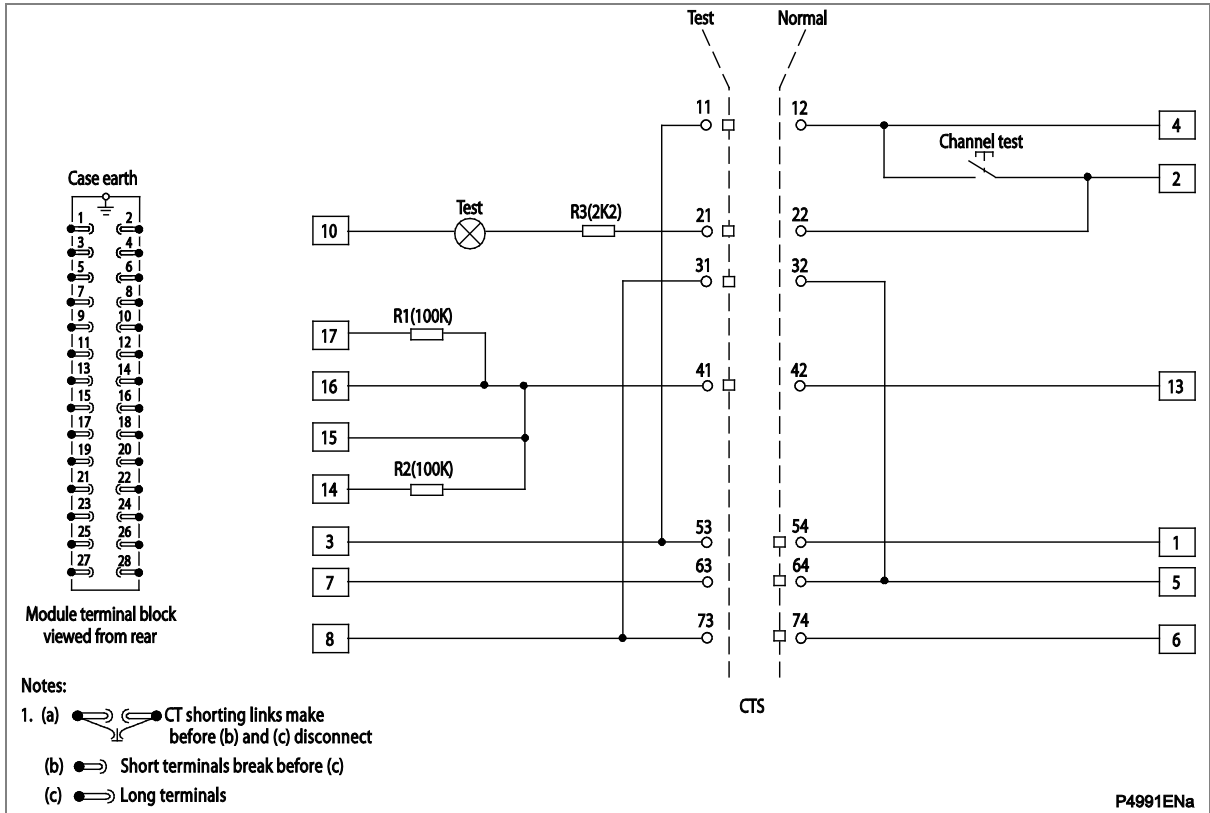

Figure 20: MMLZ 21 channel test switch - intertrip

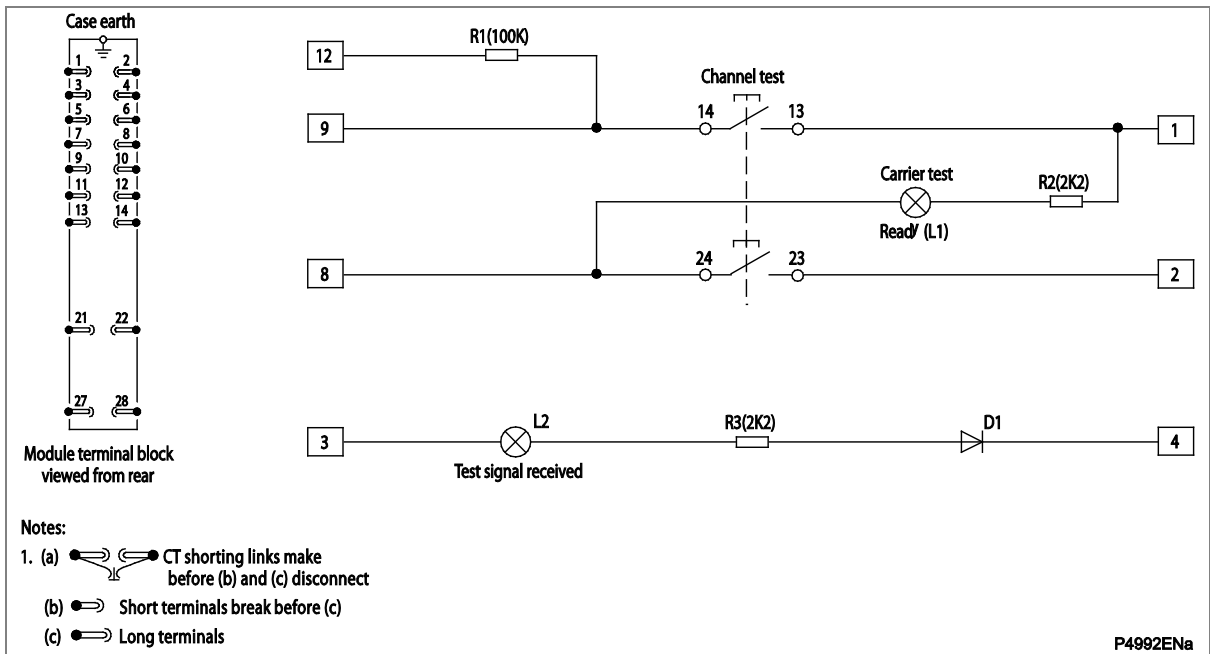

Figure 21: MMLZ 22 channel test switch - distance blocking schemes

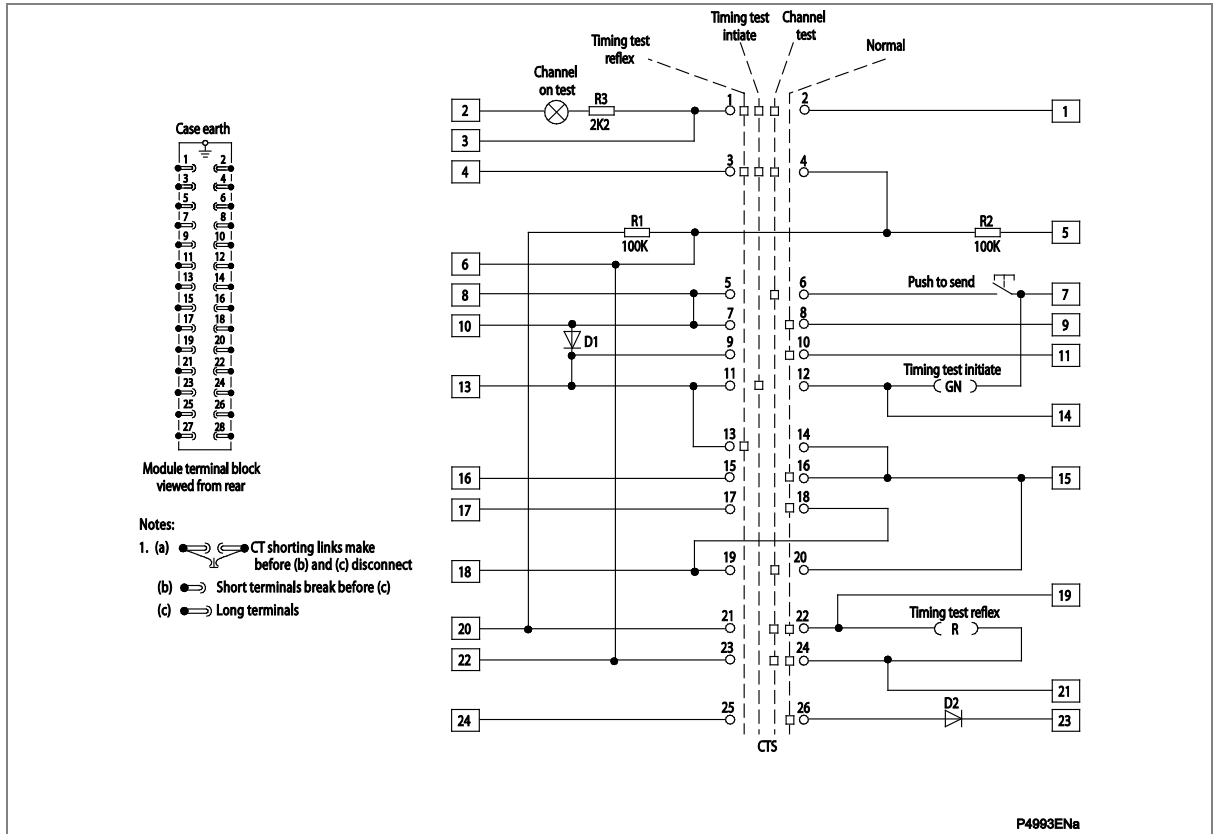

Figure 22: MMLZ 23 channel test switch - triangulated intertrip schemes

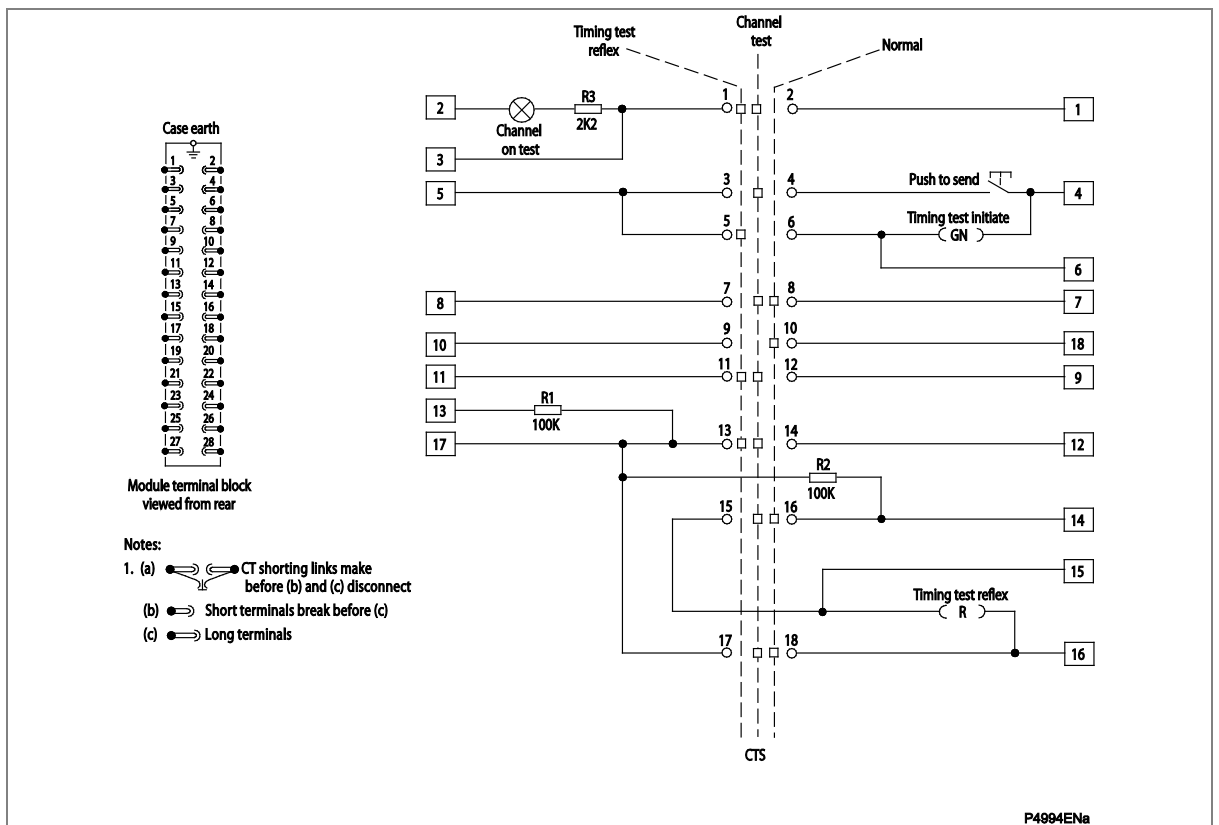

Figure 23: MMLZ 24 channel test switch - receive intertrip scheme

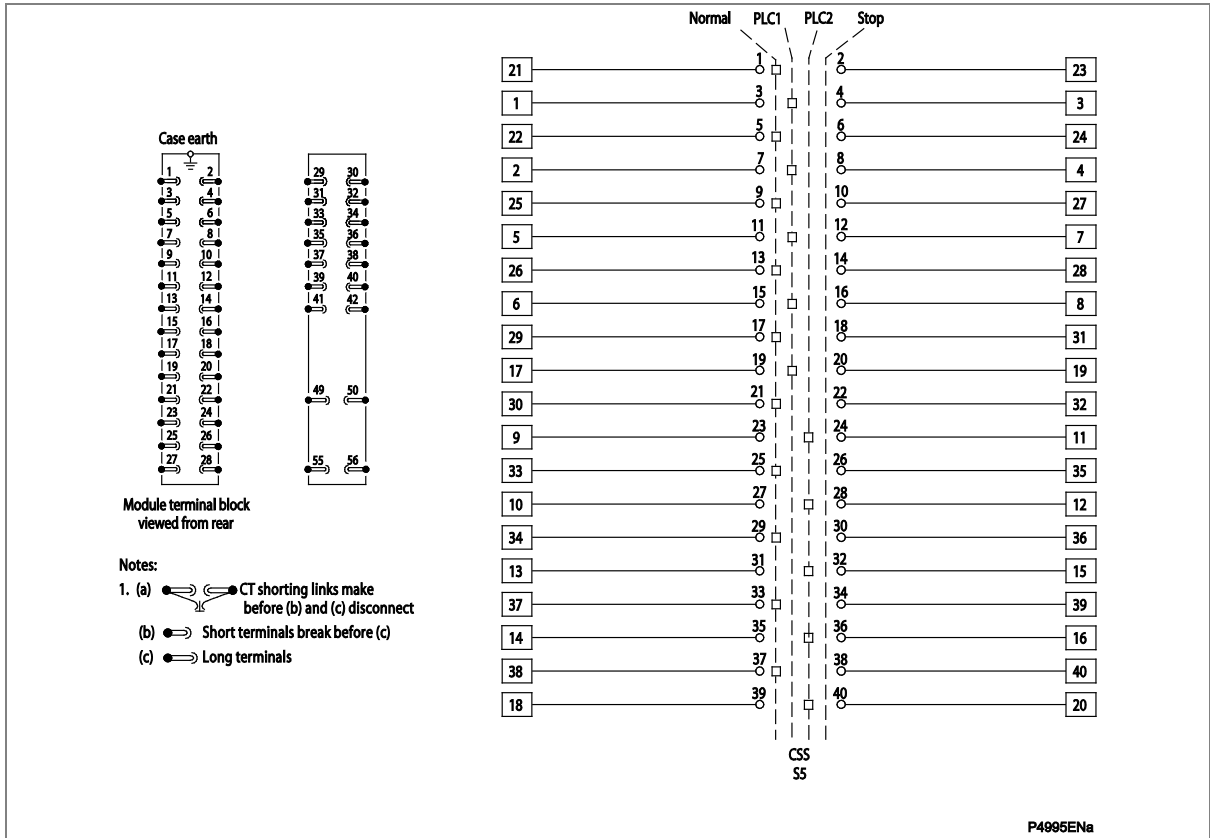

Figure 24: MMLZ 25 channel test switch - intertrip

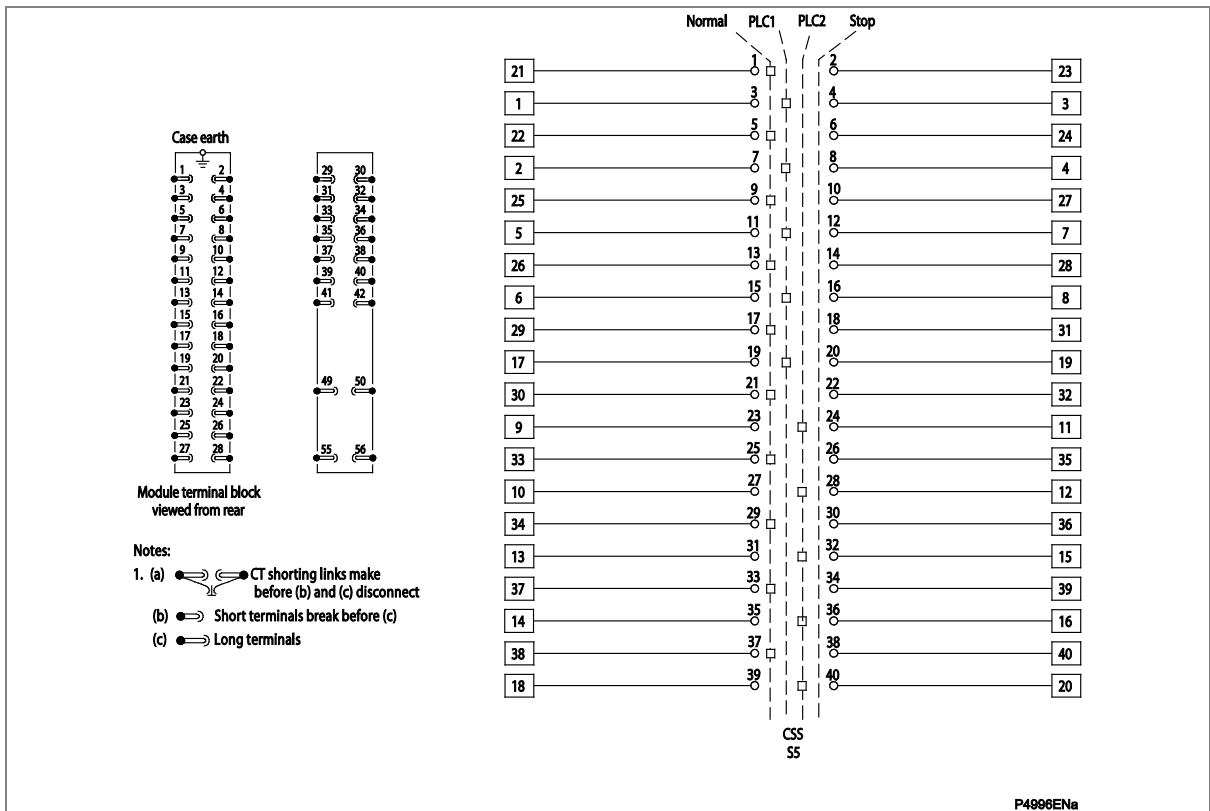

Figure 25: MMLZ 26 channel selector switches

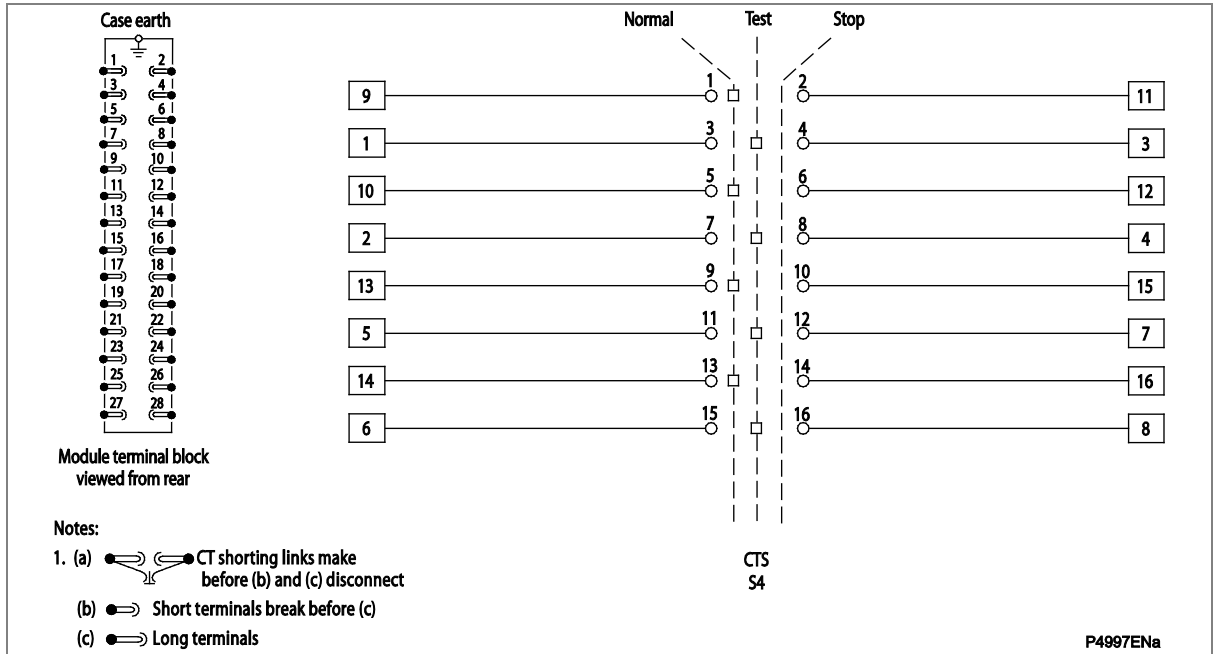

Figure 26: MMLZ 27 channel selector switches

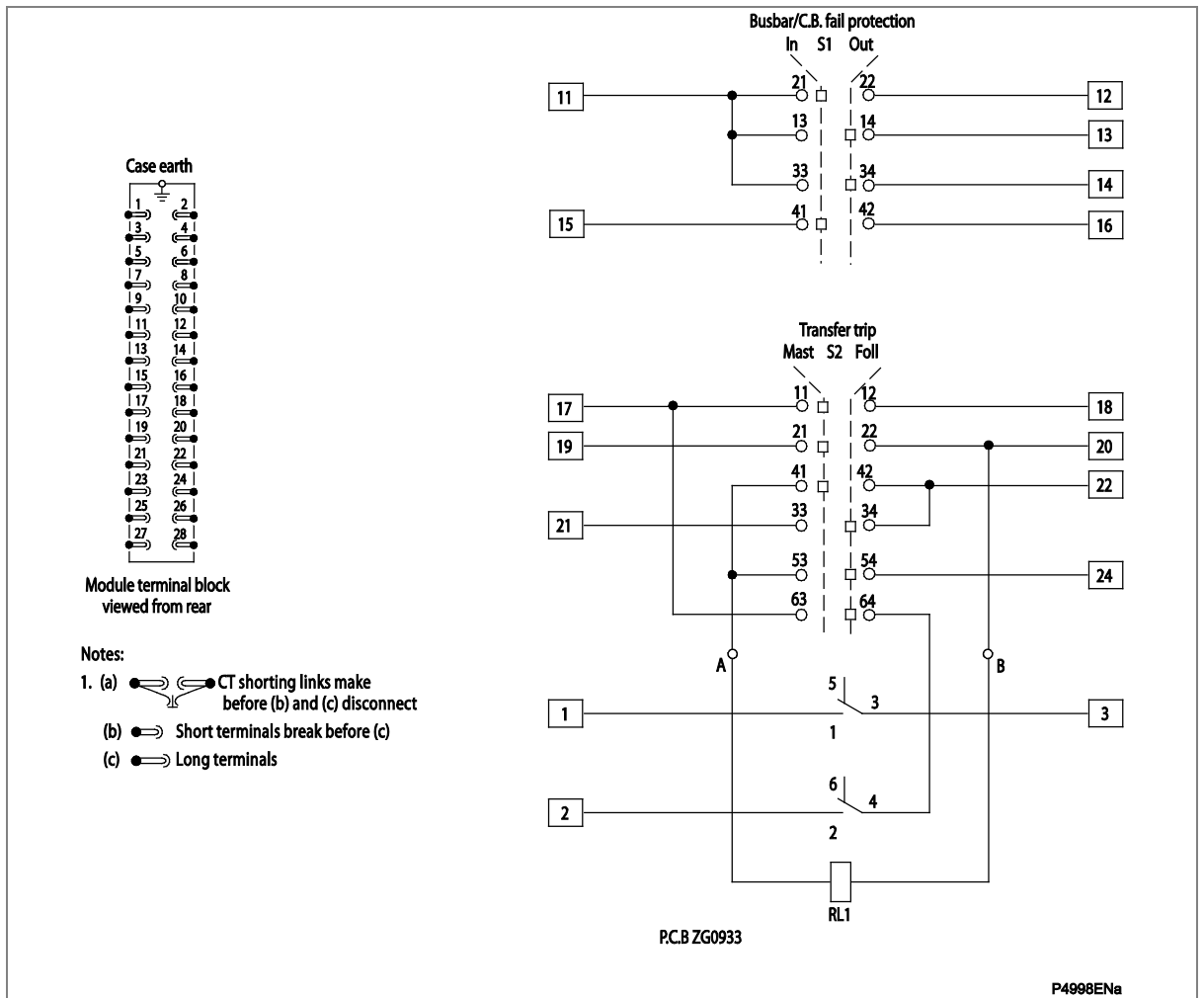

Figure 27: MMLZ 28 switching modules

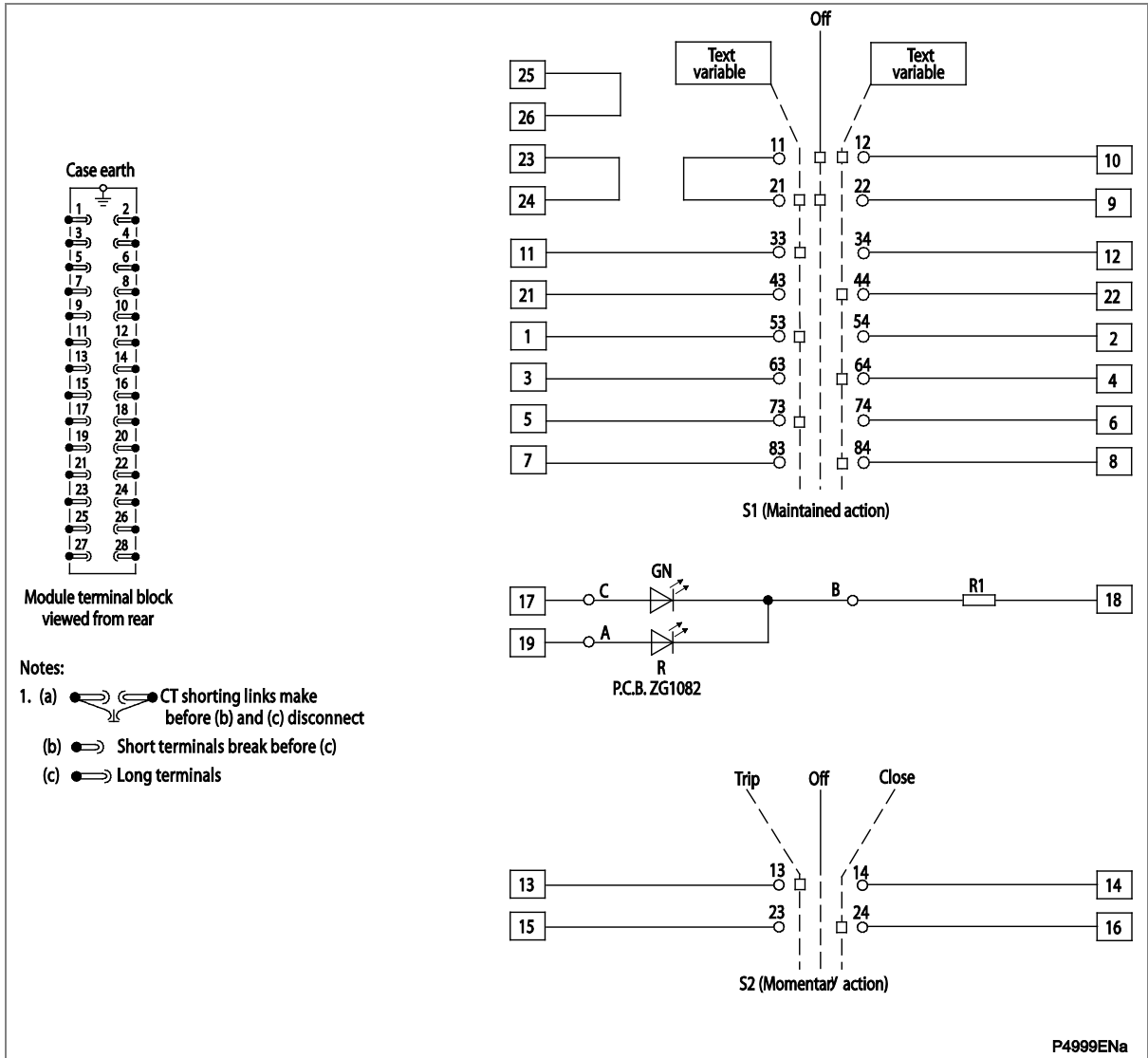

Figure 28: MMLZ 29 switching modules

RATINGS

AC Current	
Nominal current (In)	5 A

Auxiliary Voltage (Vx)	
Auxiliary voltage (dc)	24V, 48V, 110V
Recommended maximum fuse rating 6A Red Spot fuse or equivalent	

Standard Contacts	
Maximum continuous current	5 A
Power rating for 1 x 10 ⁶ operations:	
Auxiliary voltage Vdc power (W)	24 Vdc 100 W 48 Vdc 85 W 110 Vdc 65 W
High Voltage (Dielectric) Withstand	
IEC Compliance	IEC 60255-5: 1977
Between independent circuits, with terminals on each independent circuit connected together	2 kV ac rms for 1 minute
Between all case terminals and the case earth	2 kV ac rms for 1 minute
Across normally open contacts	1 kV ac rms for 1 minute

High Impulse Voltage	
IEC Compliance	IEC 60255-5: 1977
Between all independent circuits	Front time: 1.2 μ s, Time to half-value: 50 μ s, Peak value: 5 kV, 0.5 J
Between all terminals of the same circuit (except output contacts)	Front time: 1.2 μ s, Time to half-value: 50 μ s, Peak value: 5 kV, 0.5 J
Between all terminals connected together and case earth	Front time: 1.2 μ s, Time to half-value: 50 μ s, Peak value: 5 kV, 0.5 J

Switch Contacts	
Across normally open outgoing contacts	IEC 60158-1 500V ac rms and 500V dc for 1 minute

ENVIRONMENTAL CONDITIONS

Ambient Temperature Range	
Compliance	IEC 60068-2-1
Storage and transit temperature range	IEC 60068-2-2 (-25°C to +70°C)
Operating temperature range (96 hours)	-25°C to +55°C

Ambient Humidity Range	
Compliance	IEC 60068-2-3
Durability	56 days at 93% relative humidity and +40°C

Enclosure Protection	
Compliance	IEC 60529 IP50 (dust protected)

Mechanical Environment	
Compliance	IEC 60255-21-1 Class 1, BS 142 Sec. 1.5.1
Vibration	0.5g between 60 - 150Hz, 0.07 mm peak-peak between 10 - 60Hz
Durability	Contacts 3 x 10 ⁶ operations
For Standard Safety Statements for Protection and Control Relays refer to Publication R5948.	

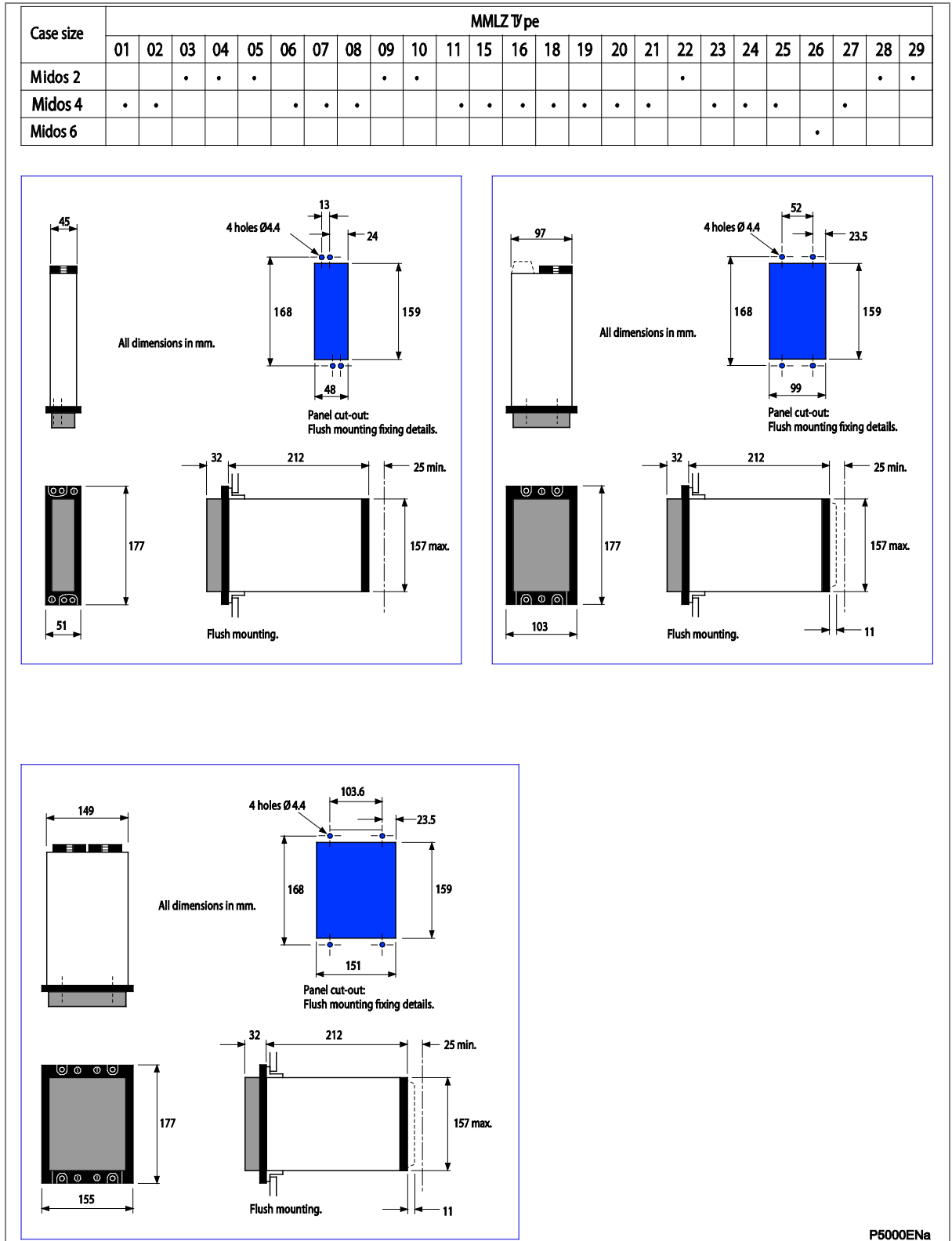

P5000ENa

Figure 29: Case outline sizes 2, 4 and 6

Information Required with Order	
Module type	MMLZ 01, 02, 03 etc.
DC auxiliary voltage	Where applicable



Imagination at work

Grid Solutions
St Leonards Building
Redhill Business Park
Stafford, ST16 1WT, UK
+44 (0) 1785 250 070
www.gegridsolutions.com/contact

© 2021 GE. All rights reserved. Information contained in this document is indicative only.
No representation or warranty is given or should be relied on that it is complete or correct or will apply to any particular project.
This will depend on the technical and commercial circumstances. It is provided without liability and is subject to change without notice.
Reproduction, use or disclosure to third parties, without express written authority, is strictly prohibited.

MMLZ/EN TDS/C